

EROSION AND SEDIMENT CONTROL NOTES

- All work shall be generally carried out in accordance with:
 - Local authority requirements,
 - EPA - Pollution control manual for urban stormwater,
 - LANDCOM NSW - Managing Urban Stormwater: Soils and Construction ("Blue Book").
 - Erosion and sediment control drawings and notes are provided for the whole of the works. Should the Contractor stage these works then the design may be required to be modified. Variation to these details may require approval by the relevant authorities. The erosion and sediment control drawings shall be implemented and adapted to meet the varying situations as work on site progresses.
 - Maintain all erosion and sediment control devices to the satisfaction of the superintendent and the local authority.
 - When stormwater pits are constructed prevent site runoff entering the pits unless silt fences are erected around pits.
 - Minimise the area of site being disturbed at any one time.
 - Protect all stockpiles of materials from scour and erosion. Do not stockpile loose material in roadways, near drainage pits or in watercourses.
 - All soil and water control measures are to be put back in place at the end of each working day, and modified to best suit site conditions.
 - Control water from upstream of the site such that it does not enter the disturbed site.
 - All construction vehicles shall enter and exit the site via the temporary construction entry/exit.
 - All vehicles leaving the site shall be cleaned and inspected before leaving.
 - Maintain all stormwater pipes and pits clear of debris and sediment. Inspect stormwater system and clean out after each storm event.
 - Clean out all erosion and sediment control devices after each storm event.
- Sequences Of Works**
- Prior to commencement of excavation the following soil management devices must be installed.
 - Construct silt fences below the site and across all potential runoff pits.
 - Construct temporary construction entry/exit and divert runoff to suitable control systems.
 - Construct measures to divert upstream flows into existing stormwater system.
 - Construct sedimentation traps/basins including outlet control and overflow.
 - Construct turl lined swales.
 - Provide sandbag sediment traps upstream of existing pits.
 - Construct geotextile filter pit surround around all proposed pits as they are constructed.
 - On completion of pavement provide sand bag kerb inlet sediment traps around pits.
 - Provide and maintain a strip of turl on both sides of all roads after the construction of kerbs.

WATER QUALITY TESTING REQUIREMENTS

Prior to discharge of site stormwater, groundwater and seepage water into Council's stormwater system, contractors must undertake water quality tests in conjunction with a suitably qualified environmental consultant outlining the following:

- Compliance with the criteria of the Australian and New Zealand Guidelines for Fresh and Marine Water Quality (2000)
- If required subject to the environmental consultants advice, provide remedial measures to improve the quality of water that is to be discharged into Councils storm water drainage system. This should include comments from a suitably qualified environmental consultant confirming the suitability of these remedial measures to manage the water discharged from the site into Councils storm water drainage system. Outlining the proposed, ongoing monitoring, contingency plans and validation program that will be in place to continuously monitor the quality of water discharged from this site. This should outline the frequency of water quality testing that will be undertaken by a suitably qualified environmental consultant.

EROSION AND SEDIMENT CONTROL PUMP OUT NOTES

Any accumulated water contaminated with sediment, from a sediment basin or excavation pit, is to be flocculated or filtered in order to lower the suspended solids load to less than 50mg per litre gypsum or other approved flocculant should be applied within 24 hours of the end of the storm event. The system must be spread evenly over the entire water surface. Pumping is not to occur for at least 36 hours and preferably 48 hours after application. Clean water is to be discharged to the water table via a hole ball sediment filter in a way that does not pick up sediment that has dropped to the bottom. Note: gypsum is a hydrated form of calcium sulphate and is available of many swimming pool shops and hardware stores.

EROSION AND SEDIMENT CONTROL LEGEND

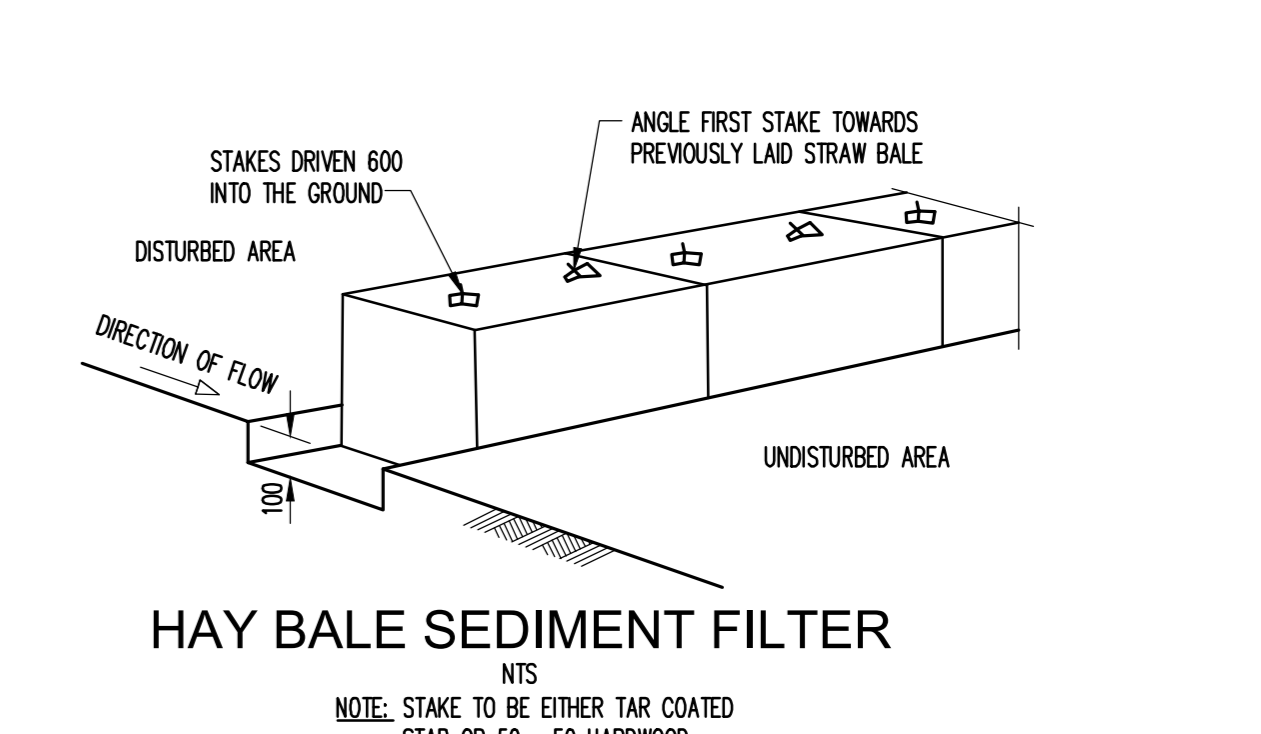
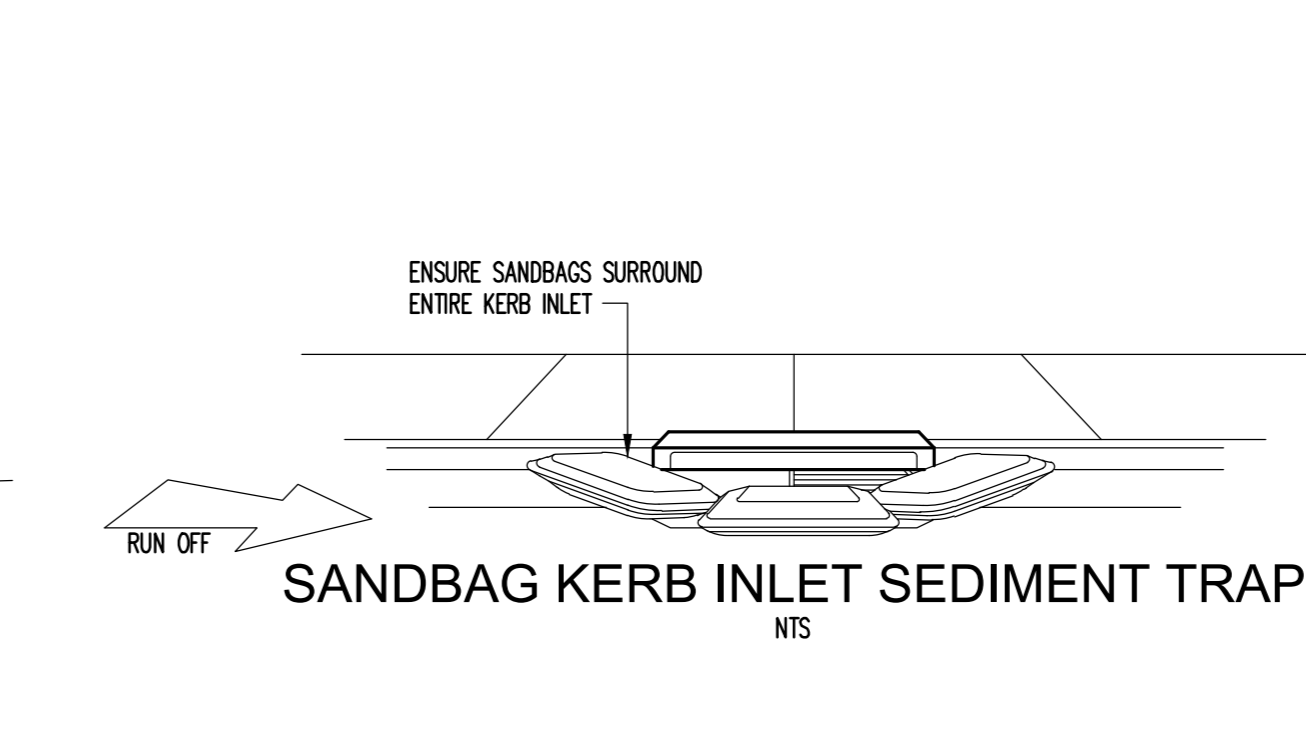
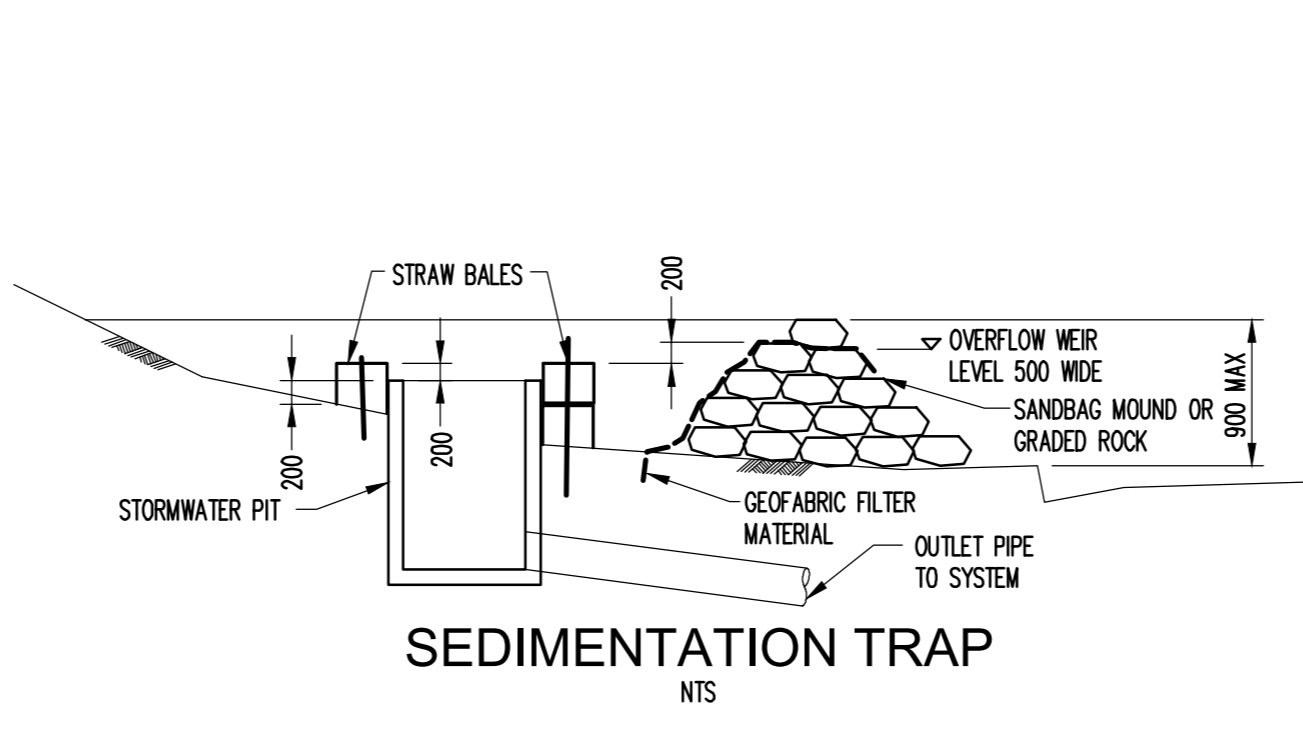
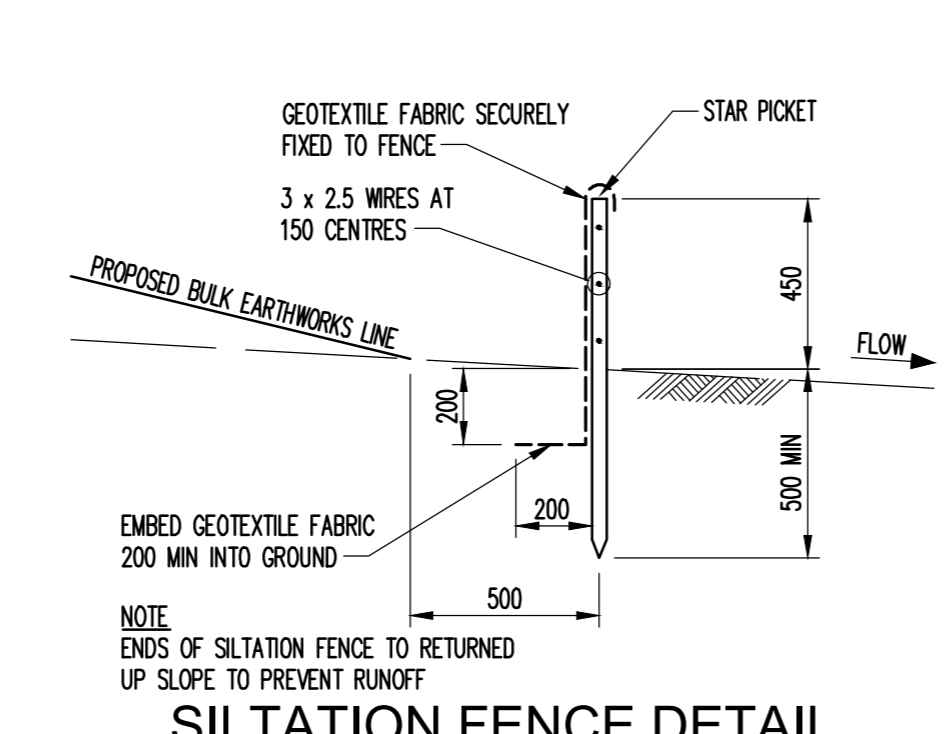
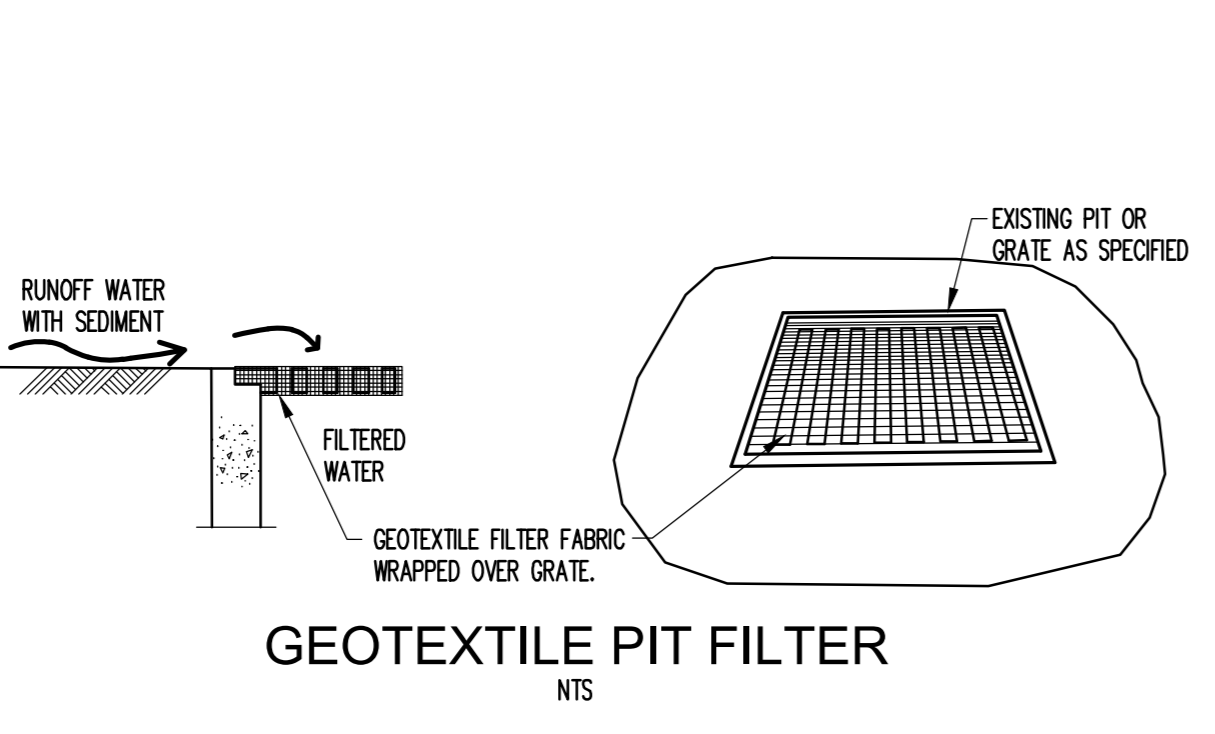
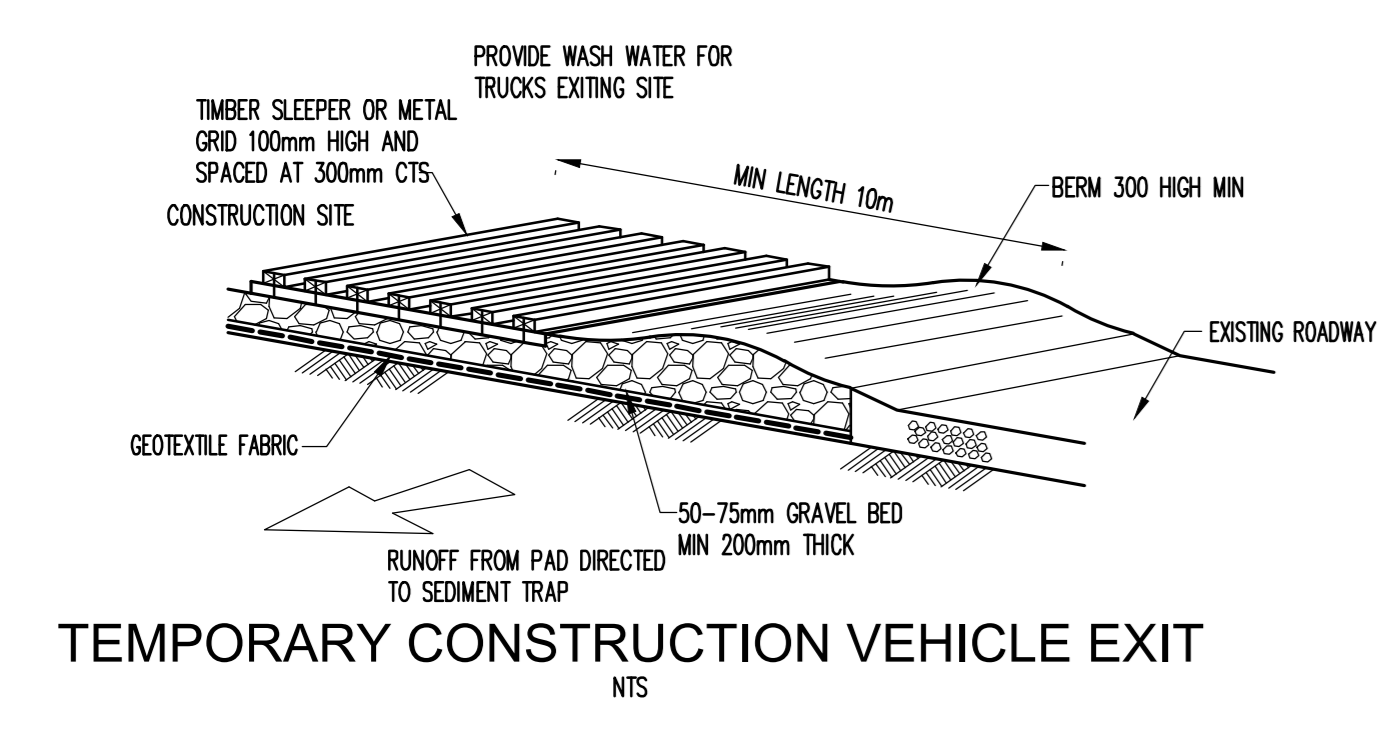
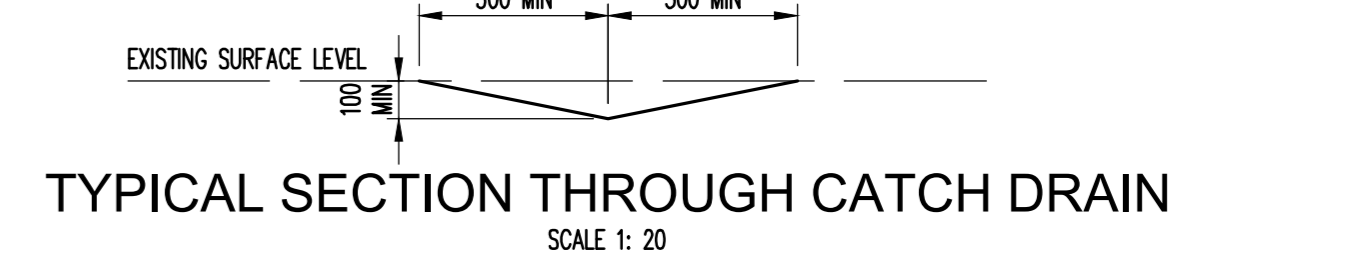
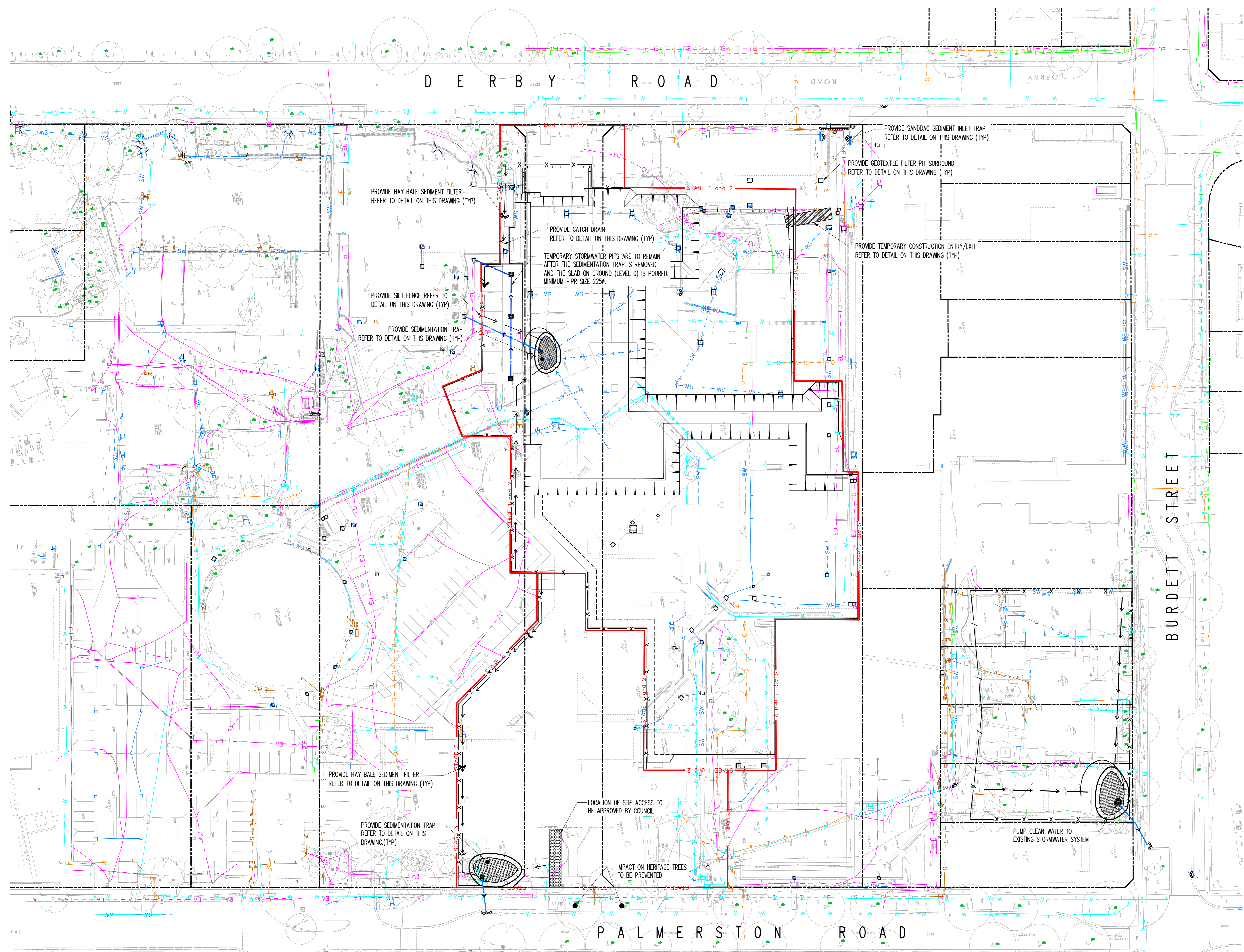
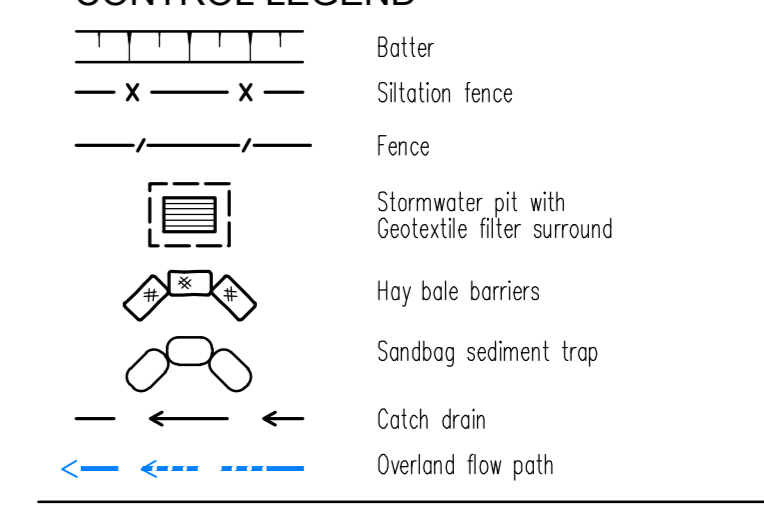

Rev	Description	Eng	Drft	Date
A	ISSUE FOR CONSTRUCTION	KH	JH	25.06.18

WATPAC Level 10, 150 Clarence Street Sydney NSW 2002

STH SILVER THOMAS HANLEY 3 Ginnery Road Glen Iris Victoria 3146

Project: **HORNSBY KU-RING-GAI HOSPITAL - STAGE 2**
Palmerston Road, Hornsby NSW 2077

Sheet Subject: **EROSION & SEDIMENT CONTROL PLAN AND DETAILS**

Civil Engineer: **TTW Taylor Thomson Whitting**
612 9439 7288 | 48 Chandos Street St Leonards NSW 2065
Scale: AD 1:400 U.N.O. Drawn: JH
Job No: Drawing No: Authorised: [Signature]
161607 CIV-DNG-00-902 A

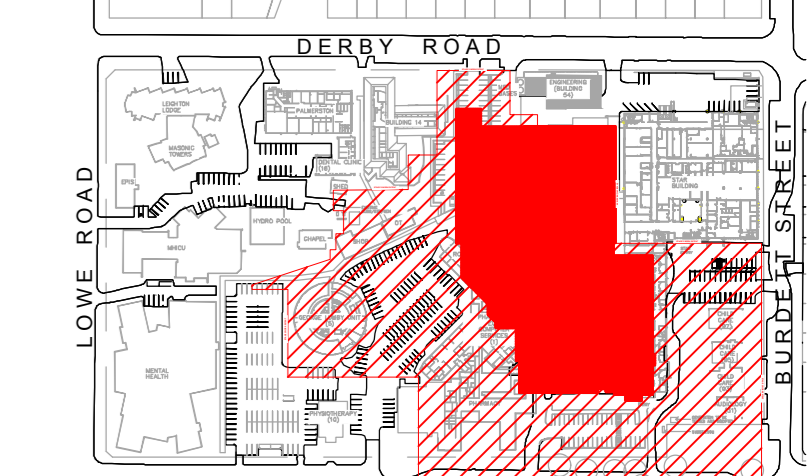

KEY PLAN

BULK EARTHWORKS CONSTRUCTION LEGEND

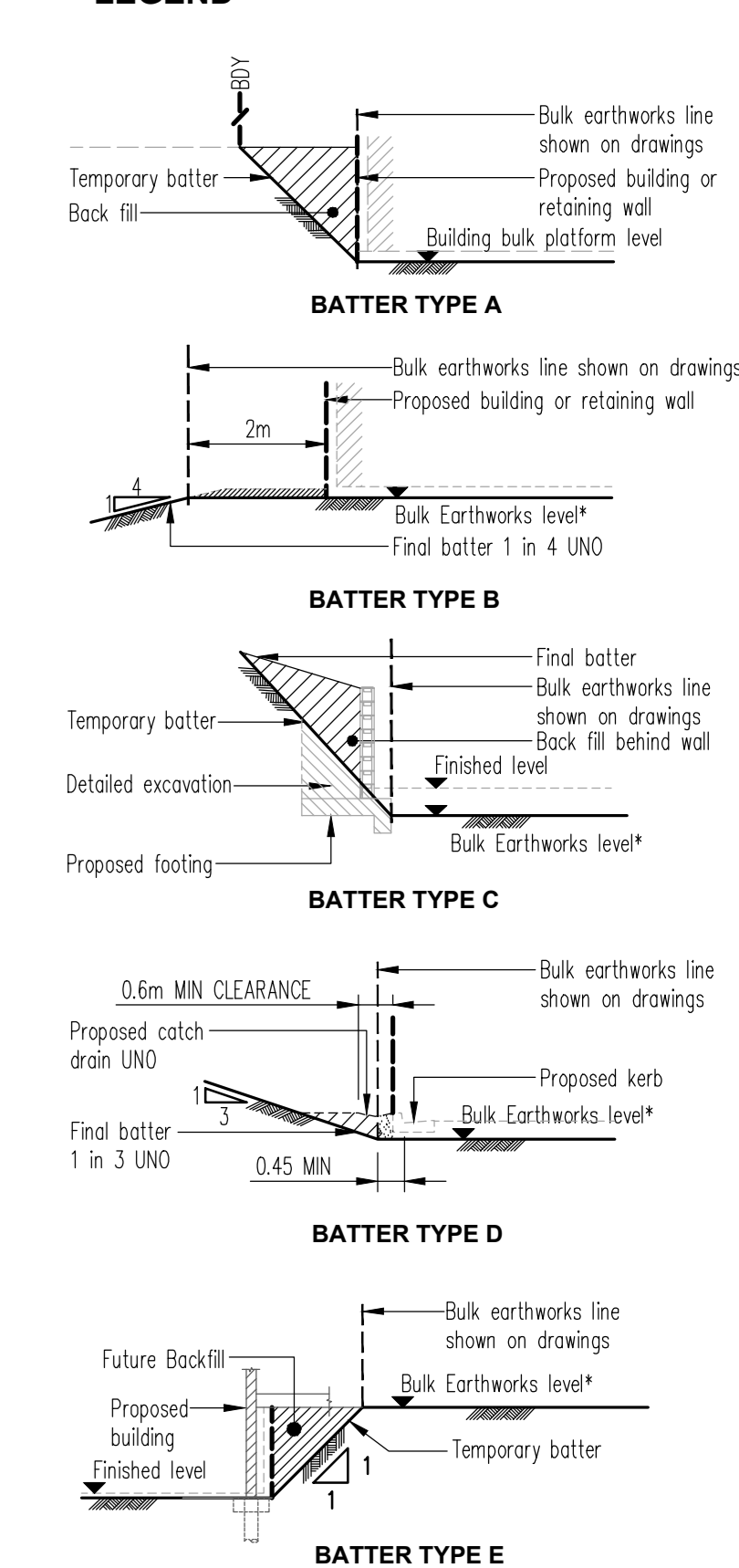

NOTE
1. * Bulk Earthworks level = Finish surface - Pavement/Slab thickness
2. Refer architects drawings for building setout
3. Bulk Earthwork drawings are for bulk excavation only. They are not to be used for detailed excavations such as fill shafts, footings, piles etc.
4. Bulk Earthwork setout refers to bulk excavation only. They are not to be used for building kerb or any other setout.

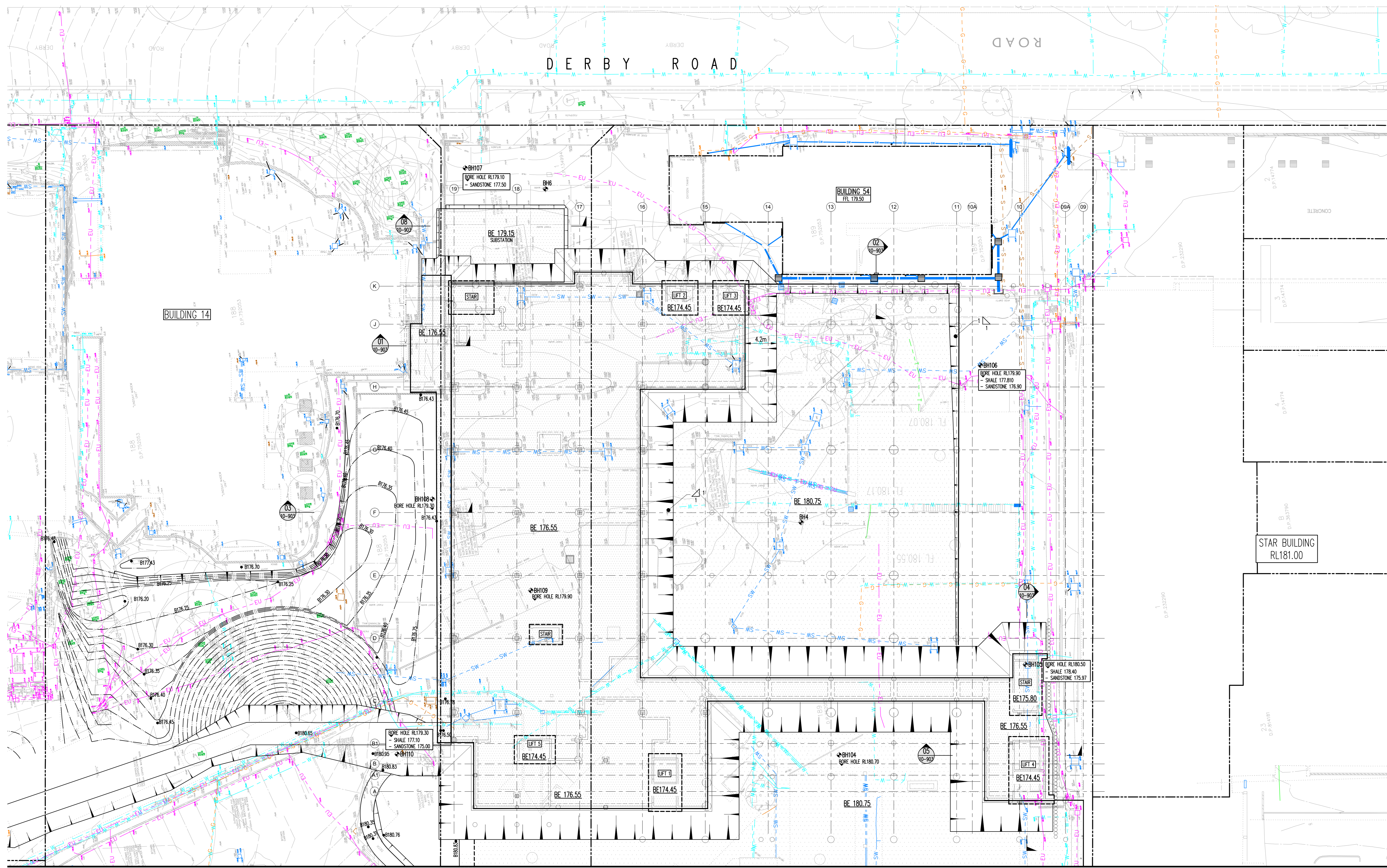

FOR CONTINUATION REFER TO DRAWING No CIV-DNG-10-902

Rev	Description	Eng	Drawn	Date
A	ISSUE FOR CONSTRUCTION	KH	JH	28.06.18

Author: **WATPAC** Level 10, 150 Clarence Street Sydney NSW 2000

Author: **STH** SILVER THOMAS HANLEY 3 Grenmore Road Glen Iris Victoria 3146

Mechanical & Electrical: ---
NSW: ---
Hydraulic & Fire: ---
NSW: ---



Level 6, 77 Pacific Highway, North Sydney NSW 2060

Project: **HORNSBY KU-RING-GAI HOSPITAL - STAGE 2**
Palmerston Road, Hornsby NSW 2077

BULK EARTHWORKS PLAN SHEET 1 OF 2



Scale: A0 1:200
Drawing: JH
Authorised: [Signature]
Job No: 161607
Drawing No: CIV-DNG-10-901
Revision: A

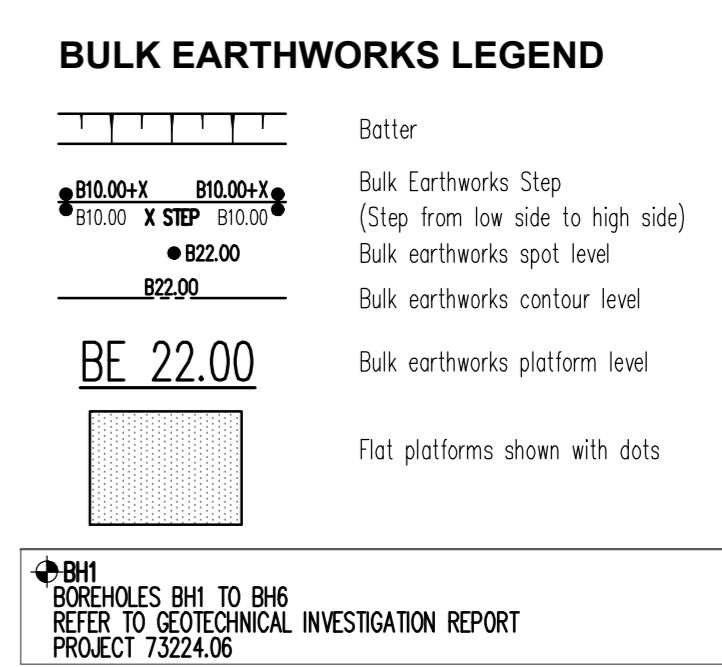

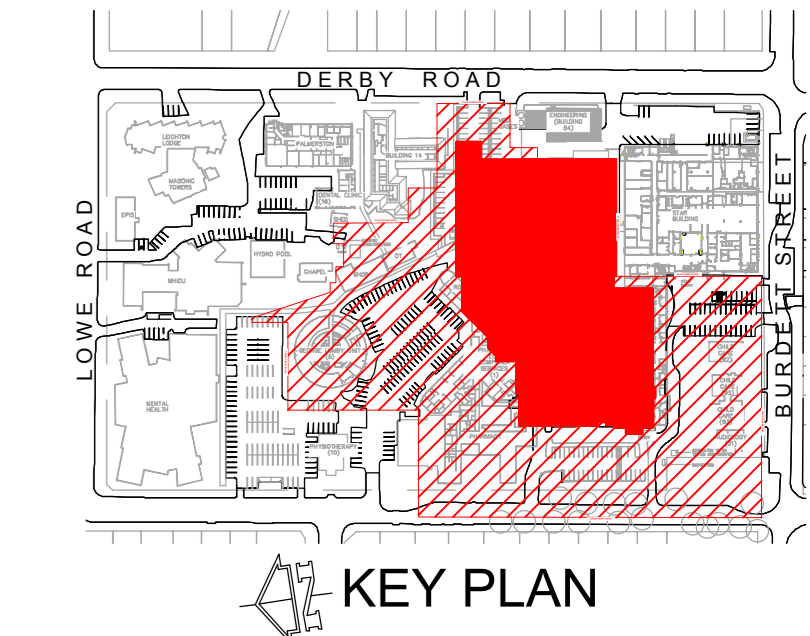

BULK EARTHWORKS CONSTRUCTION LEGEND

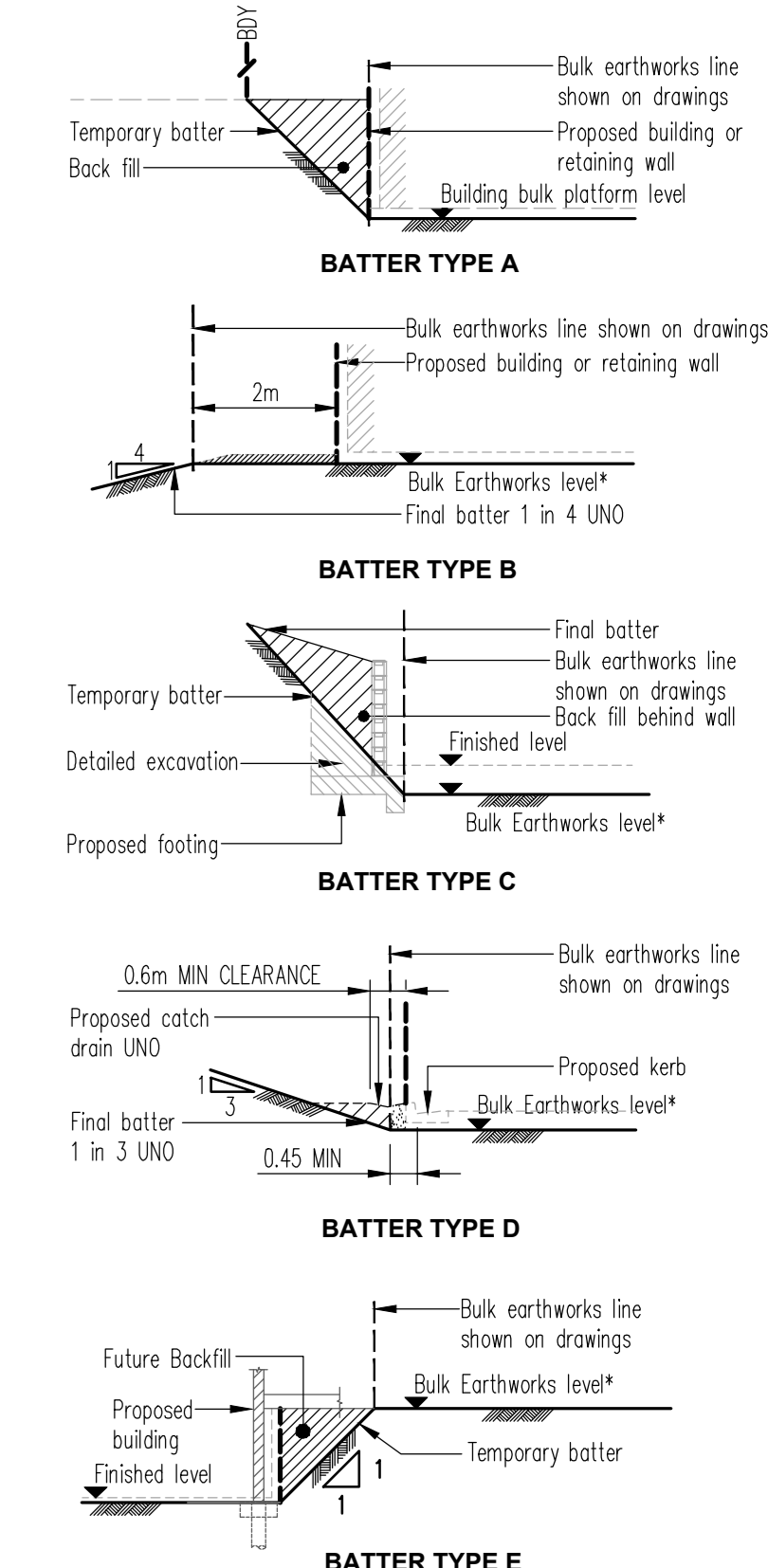

- NOTE**
- * Bulk Earthworks level = Finish surface - Pavement/flag thickness
 - Refer architects drawings for building setout
 - Bulk Earthwork drawings are for bulk excavation only. They are not to be used for detailed excavation such as lift shafts, footings, pits etc.
 - Bulk Earthwork setout refers to bulk excavation only. They are not to be used for building, kerb or any other setout.

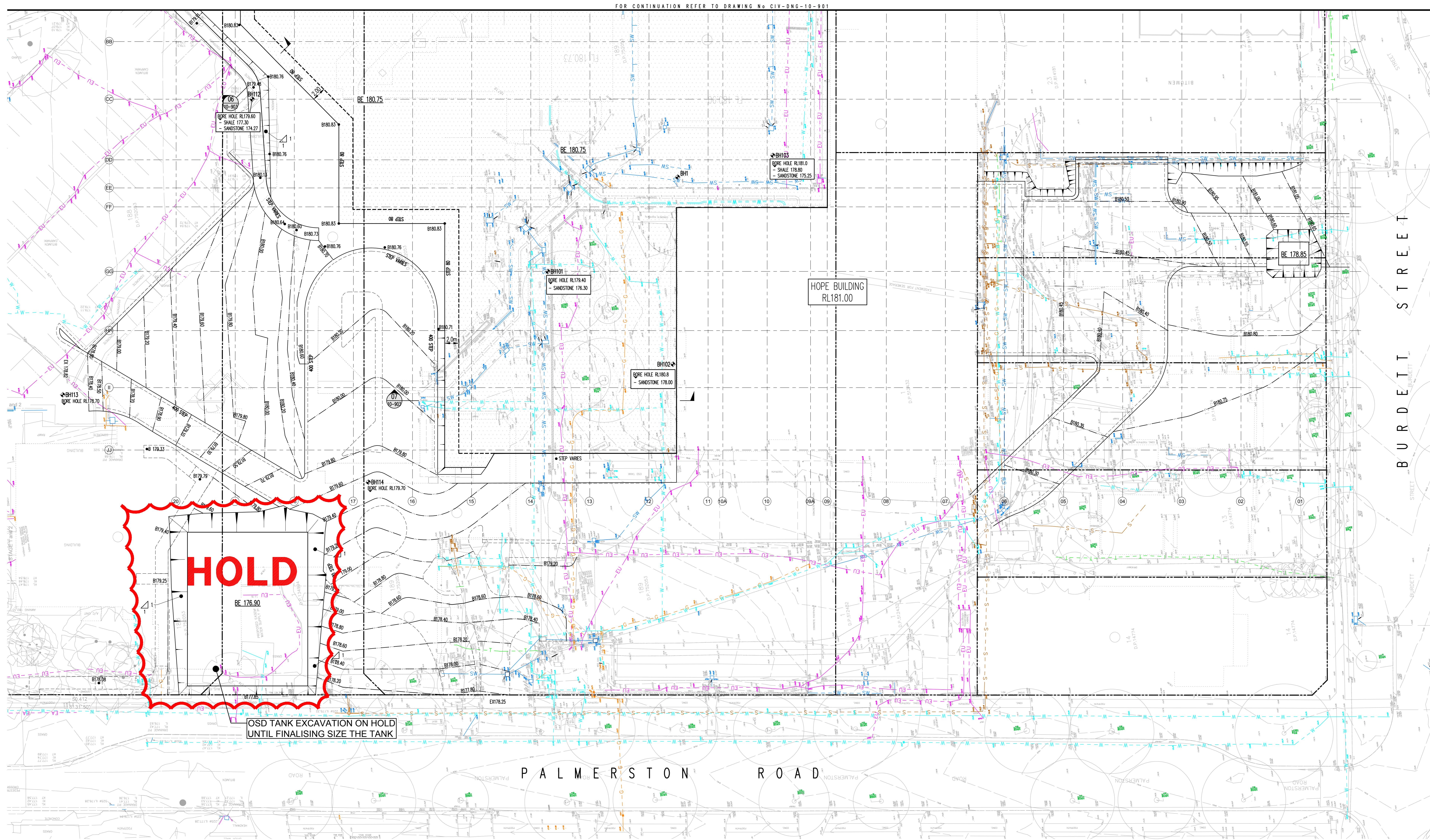

Rev	Description	Eng	Drawn	Date
A	ISSUE FOR CONSTRUCTION	KH	JH	25.06.18

Author: **WATPAC** Level 10, 155 Clarence Street Sydney NSW 2002

Author: **STH** SILVER THOMAS HANLEY 3 Clarence Road Glen Iris Victoria 3146

Mechanical & Electrical: ---

Hydraulic & Fire: ---

Client: ---



Project: **HORNSBY KU-RING-GAI HOSPITAL - STAGE 2**

Palmerston Road, Hornsby NSW 2077

Sheet Subject: **BULK EARTHWORKS PLAN SHEET 2 OF 2**

Civil Engineer: **TTW Taylor Thomson Whitting**

612 9439 7288 | 48 Chandos Street St Leonards NSW 2065

Scale: AD 1:200 Drawn: JH Authorised: [Signature]

Job No: Drawing No: Revision: **161607 CIV-DNG-10-902 A**

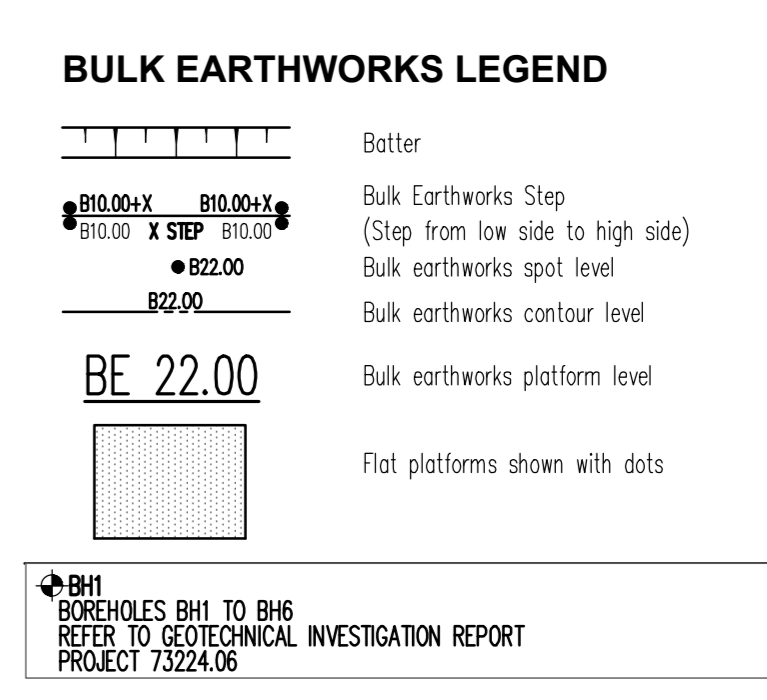

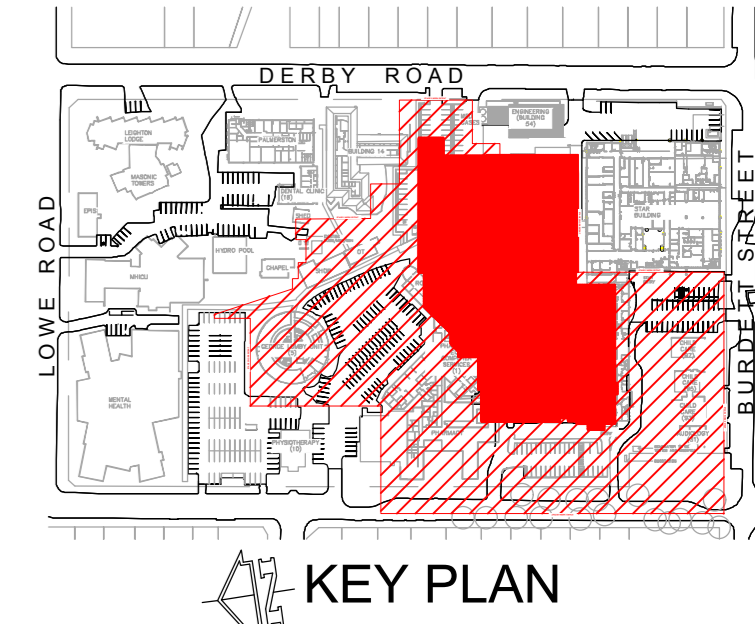

BULK EARTHWORKS CONSTRUCTION LEGEND

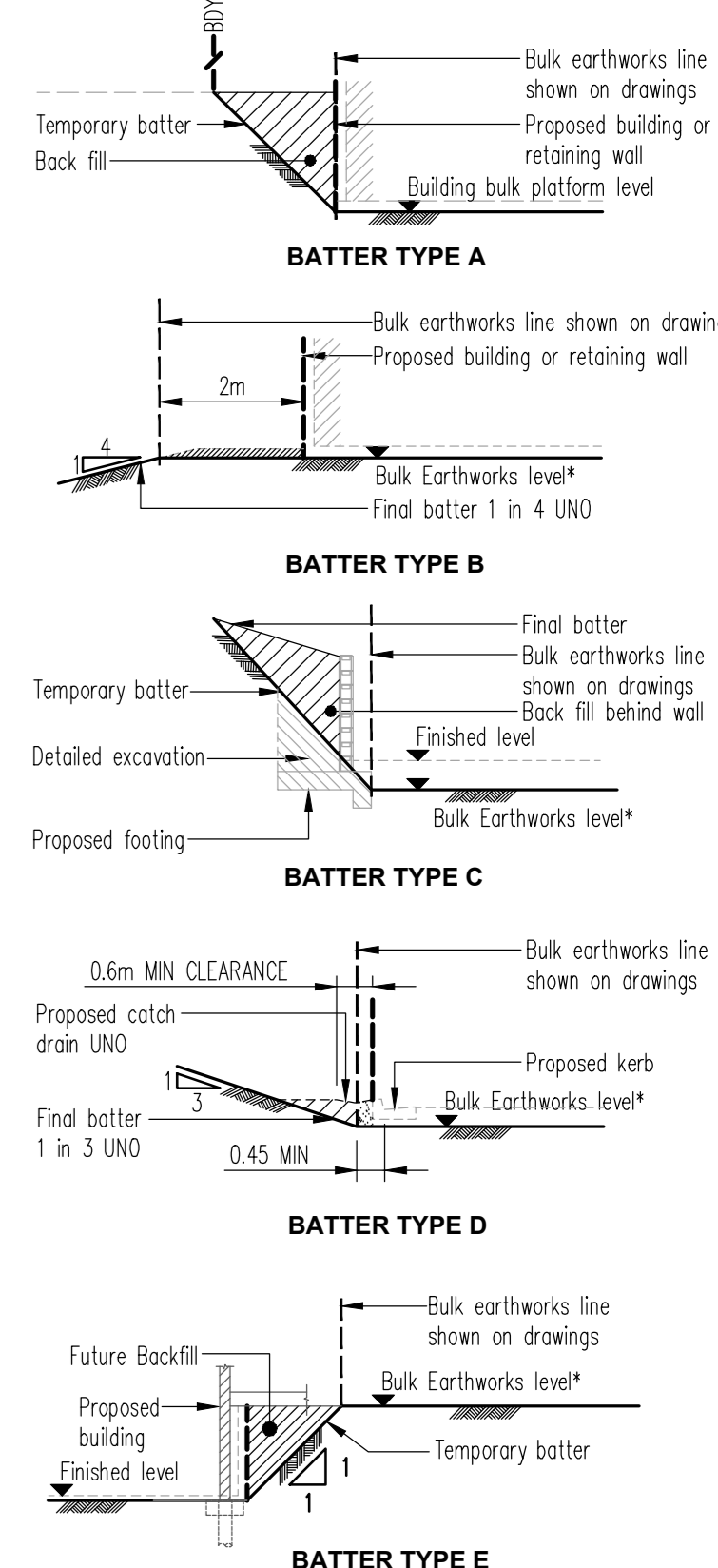

- NOTE**
- * Bulk Earthworks level = Finish surface + Pavement/Slab thickness
 - Refer architects drawings for building setout
 - Bulk Earthwork drawings are for bulk excavation only. They are not to be used for detailed excavation such as: fill shafts, footings, pits etc.
 - Bulk Earthwork setout refers to bulk excavation only. They are not to be used for building, kerb or any other setout.

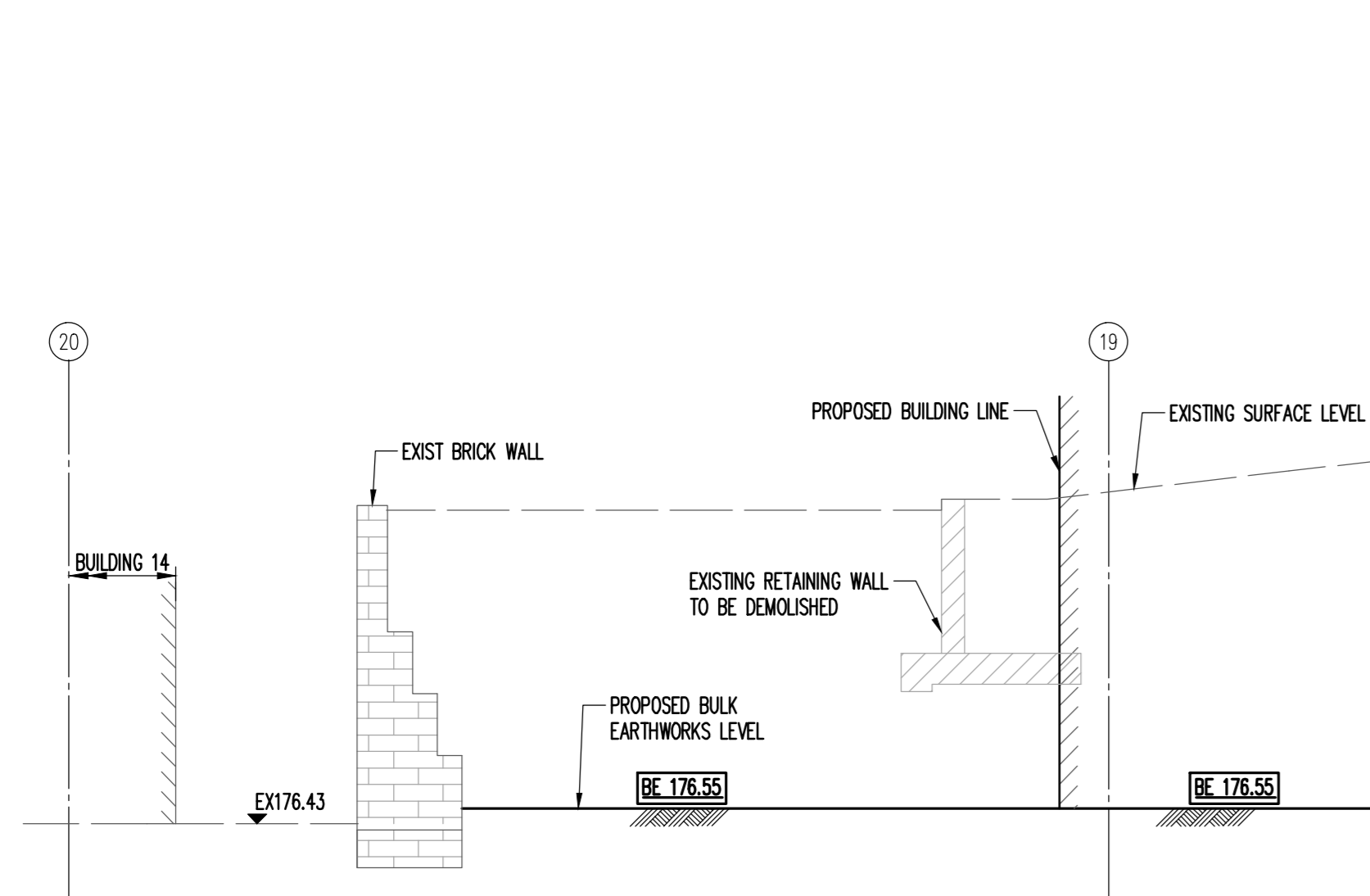

SECTION 01
SCALE 1:50

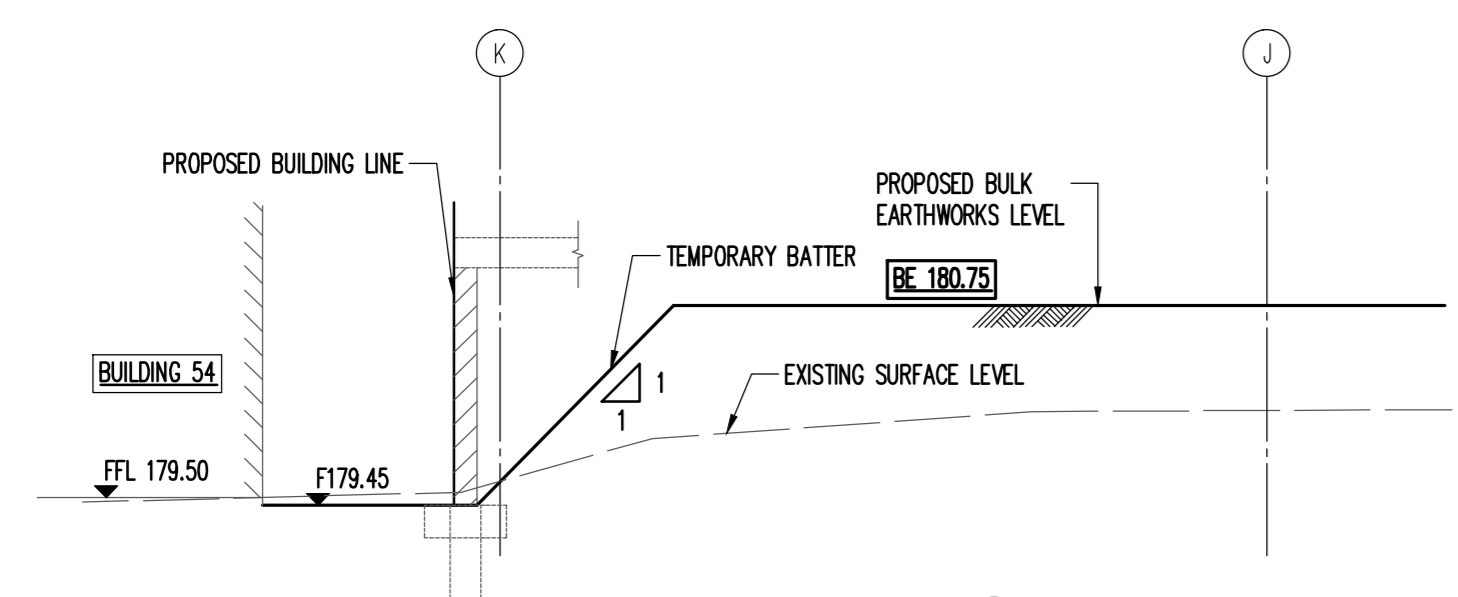

SECTION 02
SCALE 1:20

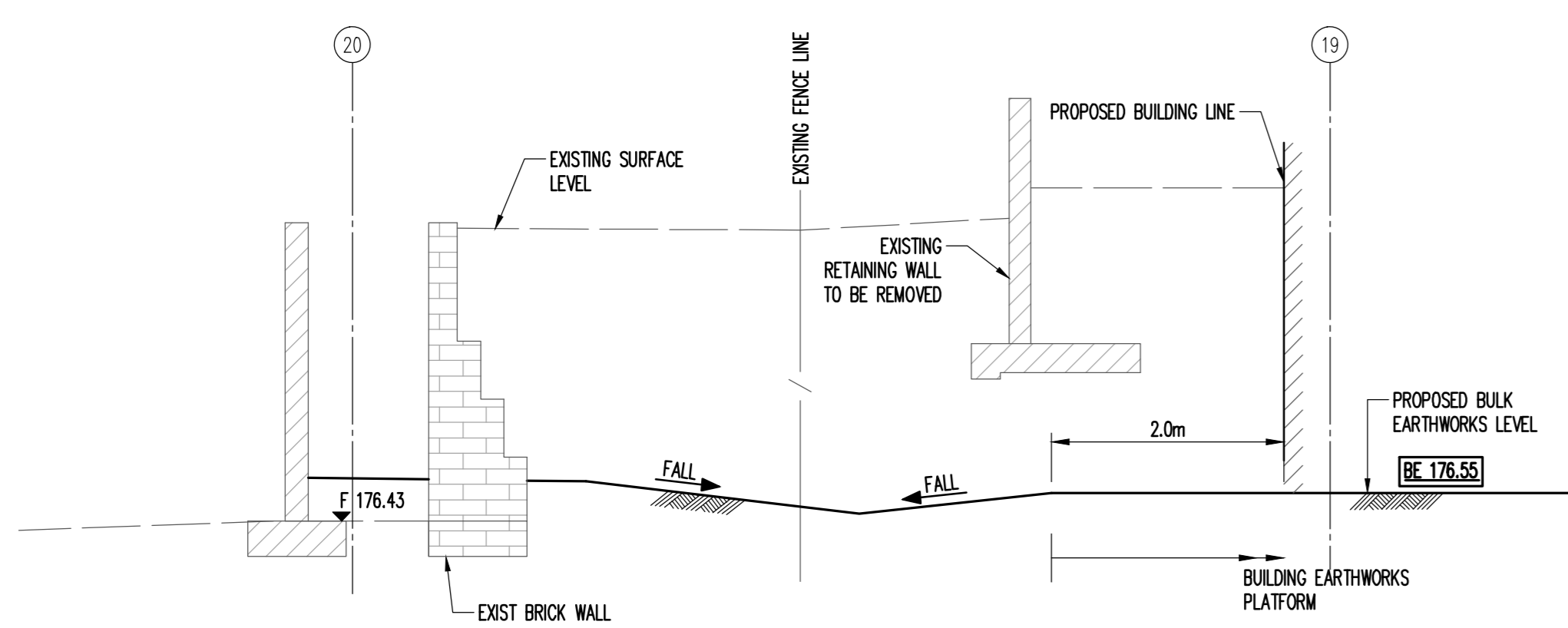

SECTION 03
SCALE 1:20

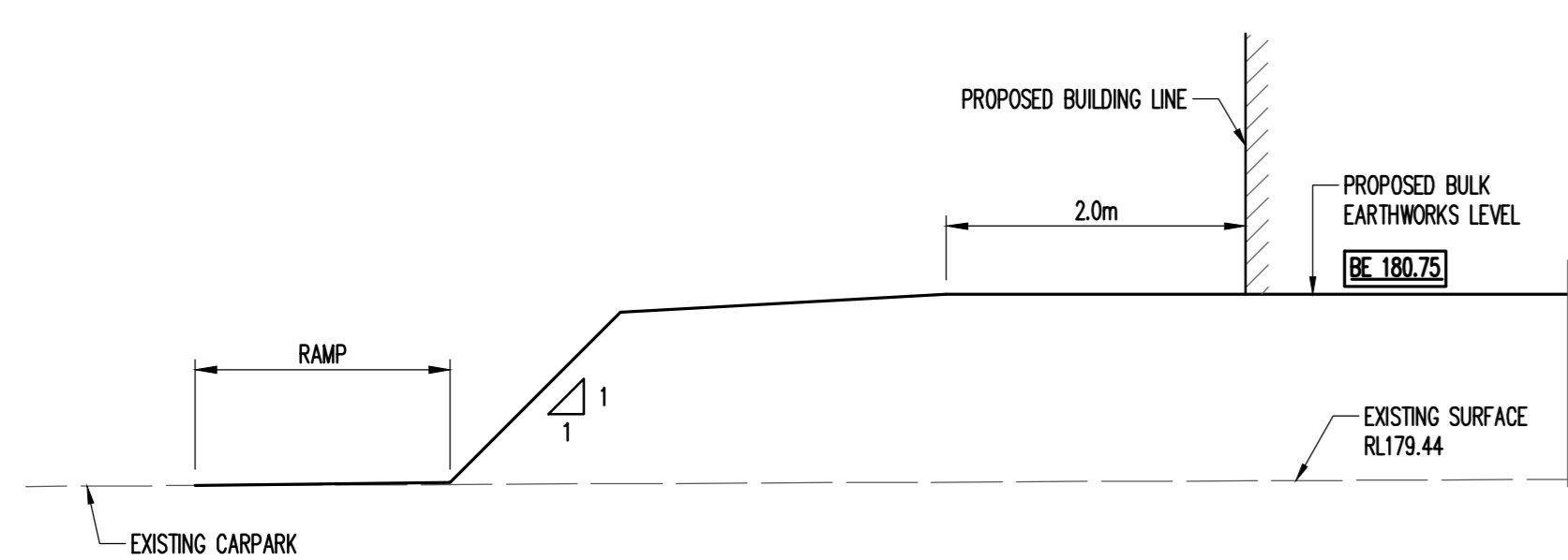

SECTION 06
SCALE 1:20

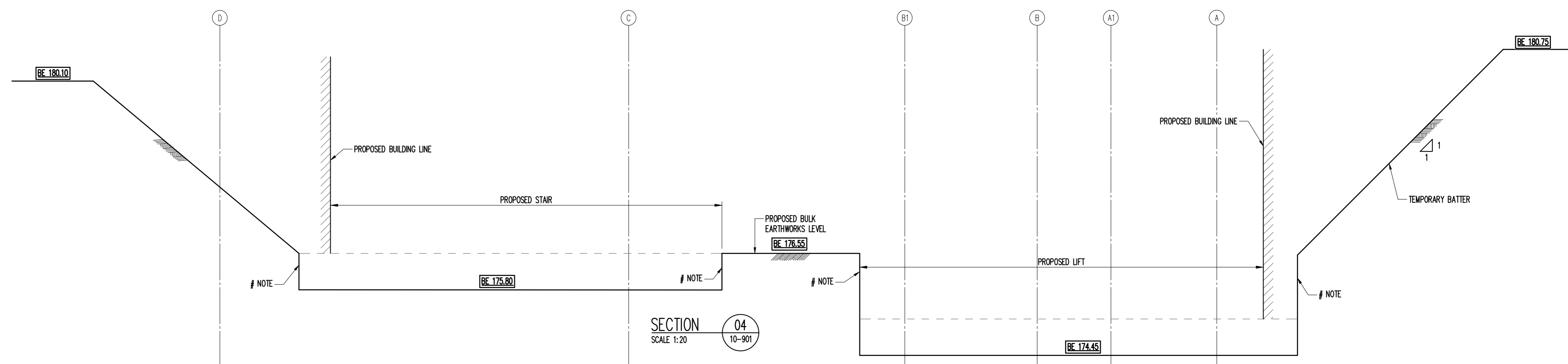

SECTION 04
SCALE 1:20

NOTE: SANDSTONE AROUND RL176.00 POSSIBLE TO INCREASE BATTER GRADE REFER GEOTECH REPORT

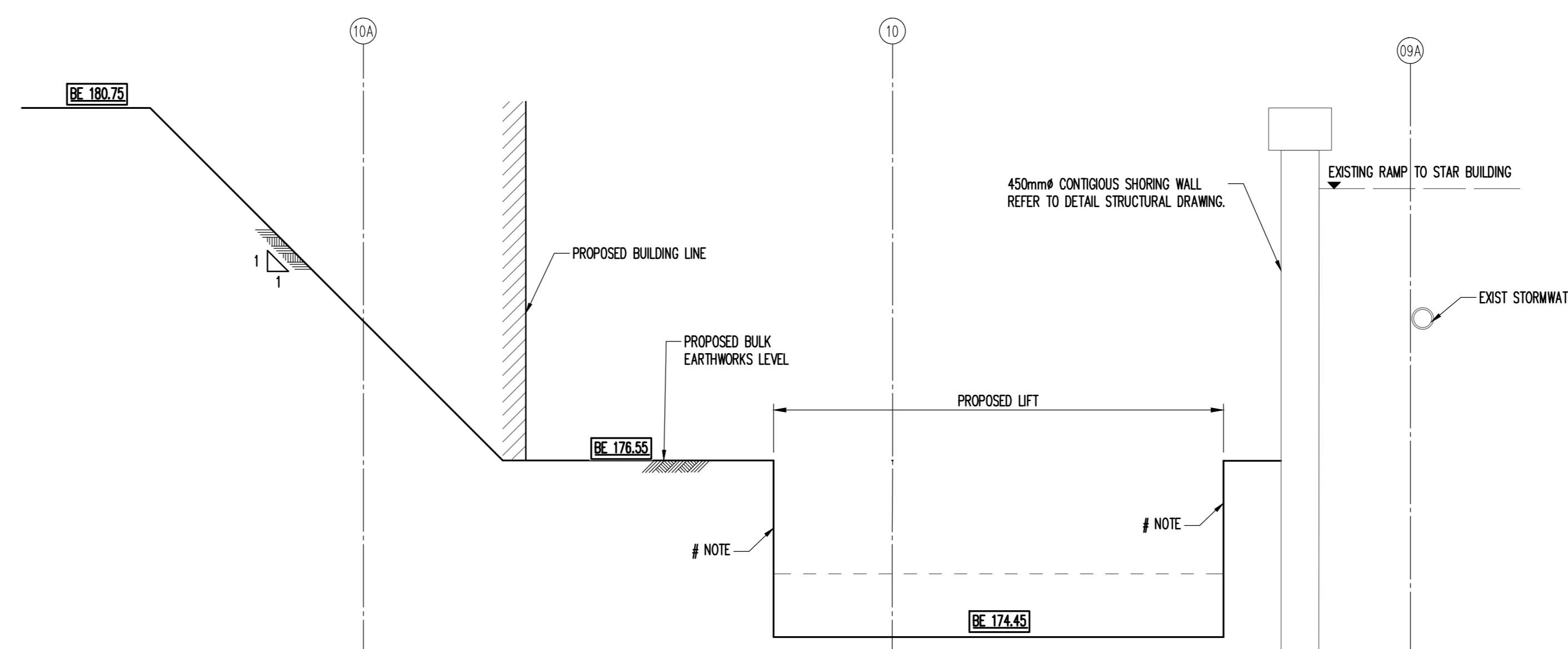

SECTION 05
SCALE 1:20

NOTE: SANDSTONE AROUND RL176.00 POSSIBLE TO INCREASE BATTER GRADE REFER GEOTECH REPORT

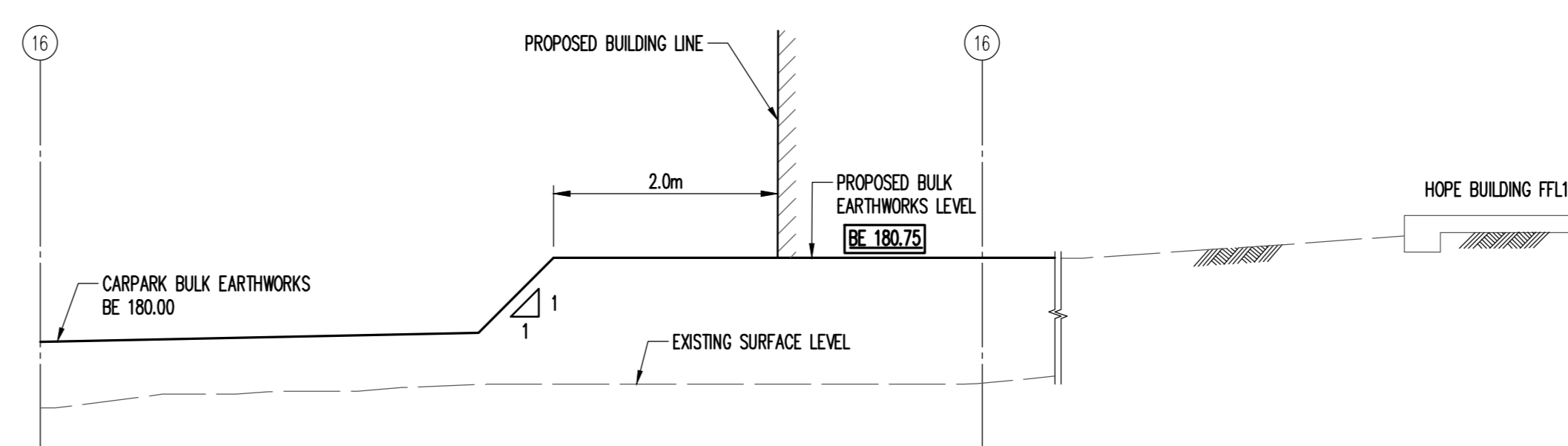

SECTION 07
SCALE 1:20

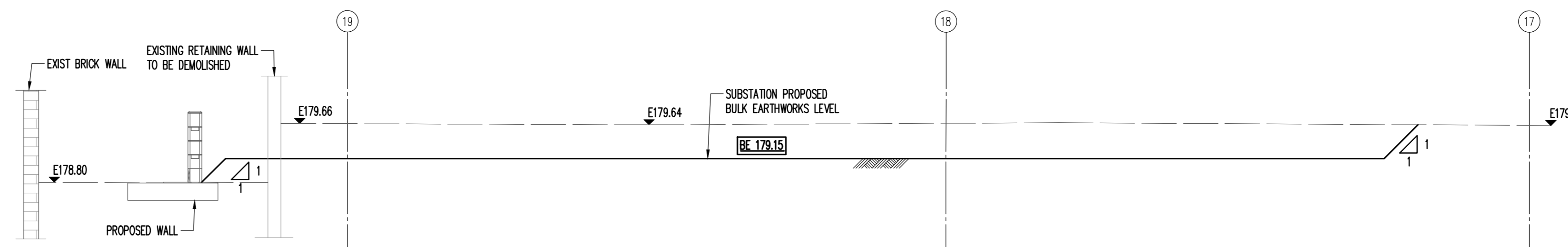

SECTION 08
SCALE 1:20

Rev	Description	Eng	Draft	Date
A	ISSUE FOR CONSTRUCTION	KH	JH	28.06.18

Author: **WATPAC** Level 10, 155 Clarence Street Sydney NSW 2000

Architect: **STH** SILVER THOMAS HANLEY 3 Glenam Road Glen Iris Victoria 3146

Mechanical & Electrical	---
Hydraulic & Fire	---
	NSW
	NSW

Client:



Level 8, 77 Pacific Highway, North Sydney NSW 2060

Project: **HORNSBY KU-RING-GAI HOSPITAL - STAGE 2**

Palmerston Road, Hornsby NSW 2077

Sheet Subject: **BULK EARTHWORKS SECTIONS SHEET**



612 9439 7288 | 48 Chandos Street St Leonards NSW 2065

Scale: A0 Drawn: AS SHOWN Authorised: JH

Job No: 161607 Drawing No: CIV-DNG-10-903 Revision: A

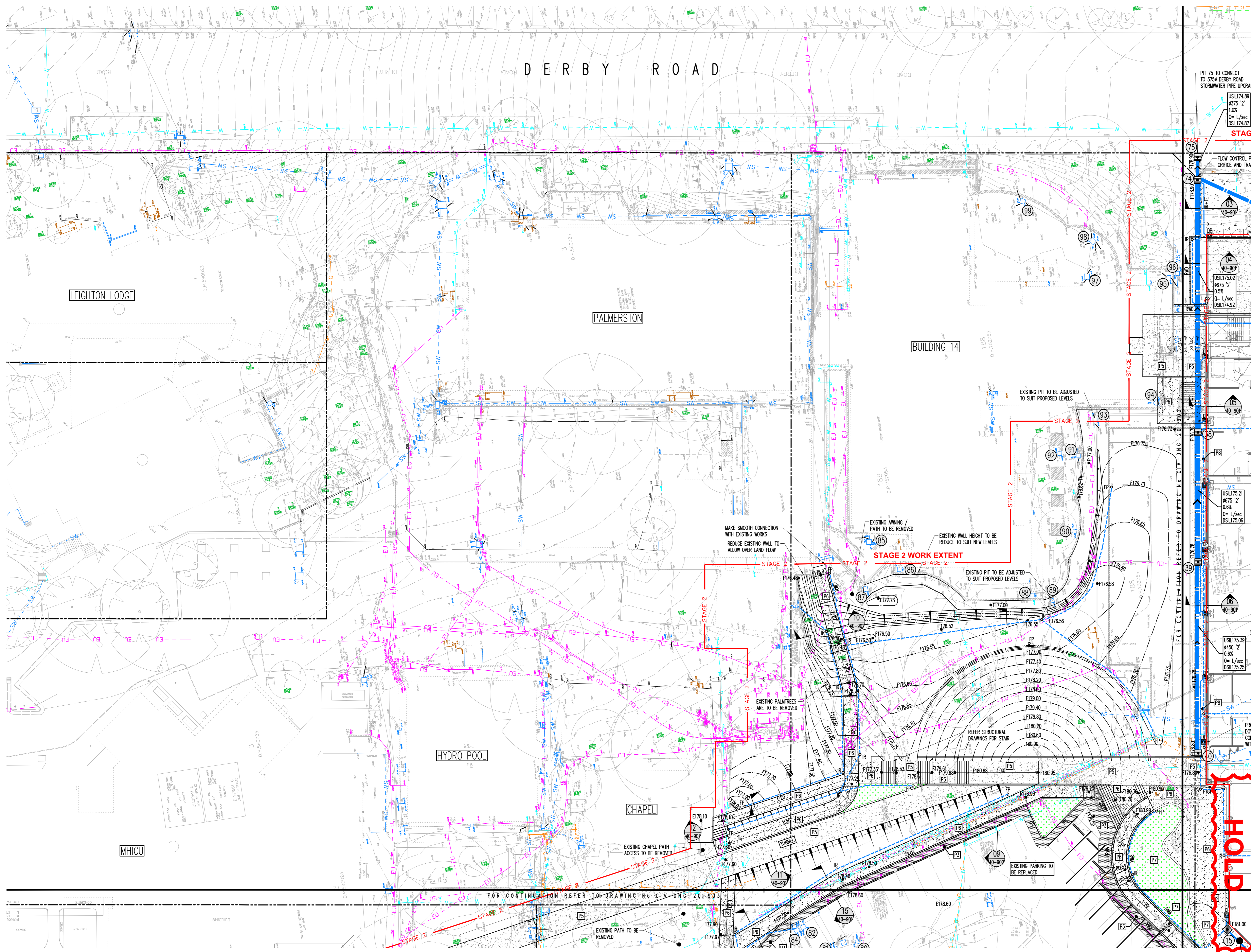
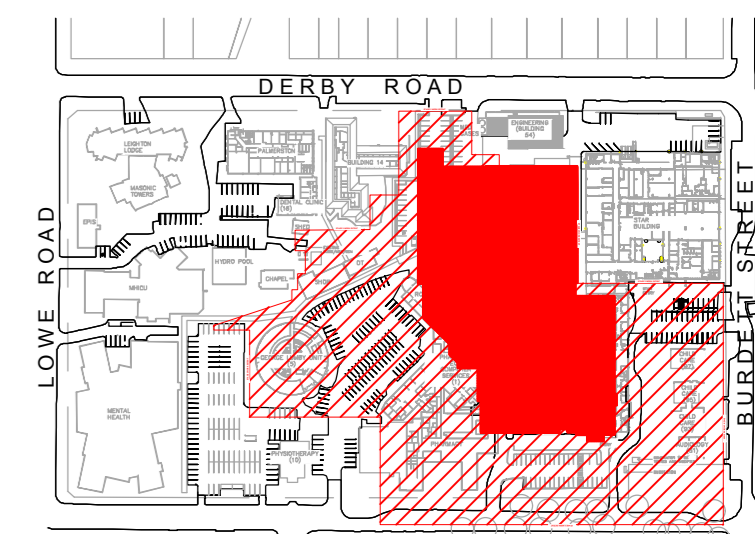

PAVEMENT LEGEND

- PAVING - 1x10⁶**
 - F1 200mm Thickness concrete (f_c=20MPa) with 5.82 fabric (40 top cover) on 100mm Compacted thickness fine crushed rock (D08 20) on 400mm 6% lime stabilised existing subgrade
- ROAD PAVEMENT ASPHALT 1 x 10⁶**
 - F2 50mm Thickness asphaltic concrete (AC10) on 100mm Compacted thickness fine crushed rock (D08 20) on 300mm Compacted thickness fine crushed rock (D05 40) on Minimum CSR 3% (allow to lime stabilise subgrade to increase CSR)
- ASPHALT CONNECTION TO EXISTING - 1x10⁶**
 - F3 50mm Existing asphalt to be milled and remove the required depth basecourse materials and place 50mm Thickness asphaltic concrete (AC10) on 100mm Compacted thickness fine crushed rock (D08 20) on 300mm Compacted thickness fine crushed rock (D05 40) on 400mm 6% lime stabilised existing subgrade
- DRIVEWAY TO HORNSBY COUNCIL REQUIREMENTS - 1x10⁶**
 - F4 200mm Thickness concrete (f_c=20MPa) with 2 layers of 5.82 fabric (40 cover) on 100mm Compacted thickness fine crushed rock (D08 20) on 400mm 6% lime stabilised existing subgrade
- CONCRETE SLAB**
 - F5 Refer structural drawing
- FOOTPATH - PEDESTRIAN**
 - F6 Finish to Landscape Architect specification on 120mm Thickness concrete (f_c=20MPa) with expansion joints at max 1.5m centres and weakened plane joints at max 1.5m centres on 5.72 fabric (40 cover) on 50mm Sand bedding
- LANDSCAPE**
 - F7 Disturbed works to be restored with Landscaping
- GRAVEL**
 - F8 150mm Thickness decomposed granite to Landscape Architect specification on 100mm Compacted thickness fine crushed rock (D08 20) on 400mm 6% lime stabilised existing subgrade
- COUNCIL PATH**
 - F9 120mm Thickness concrete (f_c=20MPa) with expansion joints at max 1.5m centres and weakened plane joints at max 1.5m centres on 5.72 fabric (40 cover) on 50mm Sand bedding

PIT SCHEDULE

Note: Grate size does not necessarily reflect pit size, refer pit type details, shown on detail sheets - DNG-30-901

Type	Description	Cover (Clear Opening)	Number
A	Kerb inlet pit	600 x 900 Class D galvanised mild steel grate hinged to frame	72,83,34, 55,36,58
B	Surface inlet pit	900x900 Class C galvanised HEEL GUARD mild steel grate hinged to frame with Envrupod basket	38,39,40,59
		900x600 Class C galvanised HEEL GUARD mild steel grate hinged to frame	42,60
		1200x1200 Class D galvanised mild steel grate hinged to frame	41,43, 74,75
C	Junction pit	900 x 900 Class B gaver accepting grate	14,15,16
		Envrupod pit	11,12,13,14, 22,24,25, 28,27,28,30, 66,67,68,69
D	Existing pit to be reconstructed to suit new works. Grate to be replaced with Class C galvanised HEEL GUARD mild steel grate hinged to frame	18,19,23,61, 65,70,71,76, 77,78,79,89, 102,103,104, 107	
		Existing pit to remain	20,21,82,83, 64,72,80,81, 82,83,84,85, 86,88,91,92, 93,94,95, 96,97,98,99, 105,106,107, 108,109,110
E	Existing pit to be demolished and removed.	59,94,96,97, 85,103,104, 106,100,100, 100,101	
		29,30,32,33, 34,35,36,37, 46,49,50,51, 52,111,112, 113,114,115, 116,117,118, 119,120, 121,122	
F	OSD Access	1200 X 1200 Class C galvanised mild steel grate hinged to frame	1

Rev	Description	Eng	Draft	Date
A	ISSUE FOR CONSTRUCTION	GH	JH	28.06.18

WATPAC Level 10, 155 Clarence Street Sydney NSW 2000

STH SILVER THOMAS HANLEY 3 Chancery Road Glen Iris Victoria 3146

Mechanical & Electrical: NSW
Hydraulic & Fire: NSW
Civil: NSW

Project: **HORNSBY KU-RING-GAI HOSPITAL - STAGE 2**
Palmerston Road, Hornsby NSW 2077

Sheet Subject: **SITE WORKS PLAN SHEET 1 OF 4**

Civil Engineer: **TTW Taylor Thomson Whitting**
612 9439 7288 | 48 Chandos Street St Leonards NSW 2065

Scale: A0 1:200
Job No: 161607 CIV-DNG-20-901
Drawing No: JH
Revision: A

HOLD DOWNPIPE LOCATIONS TO BE COORDINATED WITH HYDRAULIC DESIGN.

HOLD

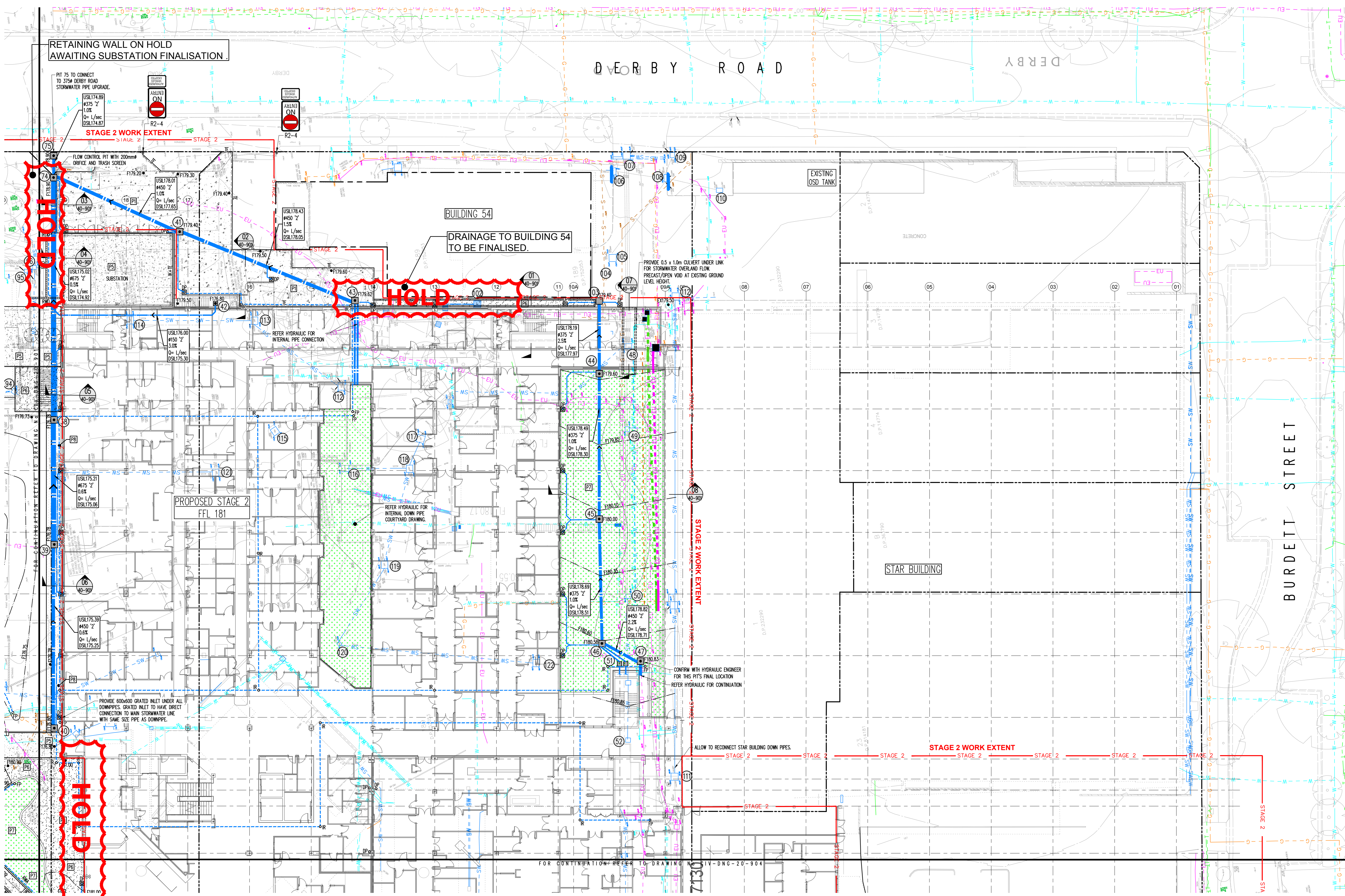
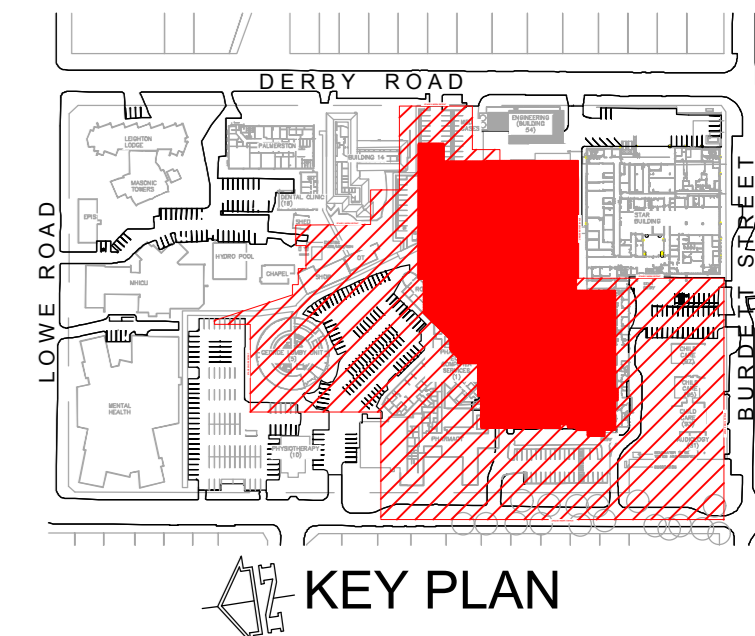

PAVEMENT LEGEND

- PAVING - 1x10⁶**
 - 200mm Thickness concrete (f=30MPa) with 3.0% fabric (40 top cover) on 100mm Compacted thickness fine crushed rock (D6820) on 400mm 6% lime stabilised existing subgrade
- ROAD PAVEMENT ASPHALT 1 x 10⁶**
 - 50mm Thickness asphaltic concrete (AC10) on 100mm Compacted thickness fine crushed rock (D6820) on 300mm Compacted thickness fine crushed rock (D5540) on 400mm 6% lime stabilised existing subgrade
 - Minimum CBR 3% (slow to lime stabilise subgrade to increase CBR)
- ASPHALT CONNECTION TO EXISTING - 1x10⁶**
 - 50mm Existing asphalt to be milled and remove the required depth basecourse materials and place 50mm Thickness asphaltic concrete (AC10) on 100mm Compacted thickness fine crushed rock (D6820) on 300mm Compacted thickness fine crushed rock (D5540) on 400mm 6% lime stabilised existing subgrade
- DRIVEWAY TO HORNSBY COUNCIL REQUIREMENTS - 1x10⁶**
 - 200mm Thickness concrete (f=30MPa) with 2 layers of 3.0% fabric (40 cover) on 100mm Compacted thickness fine crushed rock (D6820) on 400mm 6% lime stabilised existing subgrade
- CONCRETE SLAB**
 - Refer structural drawing
- FOOTPATH - PEDESTRIAN**
 - Finish to Landscape Architect specification on 120mm Thickness concrete (f=30MPa) with expansion joints at max.0m centres and weakened plane joints at max 1.5m centres on 5.7% fabric (40 cover) on 50mm Sand bedding
- LANDSCAPE**
 - Disturbed works to be restored with Landscaping
- GRAVEL**
 - 150mm Thickness decomposed granite to Landscape Architect specification on 100mm Compacted thickness fine crushed rock (D6820) on 400mm 6% lime stabilised existing subgrade
- COUNCIL PATH**
 - 120mm Thickness concrete (f=30MPa) with expansion joints at max.0m centres and weakened plane joints at max 1.5m centres on 5.7% fabric (40 cover) on 50mm Sand bedding

PIT SCHEDULE

Note: Pit size does not necessarily reflect pit size, refer pit type details shown on detail sheets **DNG-00-901**. Final internal pit dimensions are to comply with AS3500

Type	Description	Cover (Clear Opening)	Number
A	Kerb inlet pit 1800 Intel	600 x 900 Class D galvanised mild steel grate hinged to frame	7,8,5,5,4, 25,56,58
B	Surface inlet pit	900x900 Class C galvanised HEEL GUARD mild steel grate hinged to frame with Entrapods basket	38,38,40,50
		900x600 Class C galvanised HEEL GUARD mild steel grate hinged to frame	42,60
		1200x1200 Class D galvanised mild steel grate hinged to frame	41,43, 74,75
		900 x 900 Class B power accepting grate	14,15,16
D	Existing pit to be reconstructed to suit new works. Grate to be replaced with Class C galvanised HEEL GUARD mild steel grate hinged to frame	16,19,23,67, 77,78,87,89, 102,103,104	
		Existing pit to remain	20,21,62,63, 64,72,80,81, 82,83,84,85, 86,88,90,91, 92,93,94,95, 96,97,98,99, 105,106,107, 108,109,110
E	Existing pit to remain	93,94,95,96, 97,98,99, 100,101	
		Existing pit to be demolished and removed.	28,37,33,33, 34,35,36,37, 48,49,50,51, 52,111,112, 113,114,115, 116,117,118, 119,120, 121,122
F	OSD Access	1200 X 1200 Class C galvanised mild steel grate hinged to frame	10,10,10A, 108,10C,10D, 103,01

Rev	Description	Eng	Draft	Date
1	ISSUE FOR CONSTRUCTION	JH	JH	28.06.18

WATPAC Level 10, 155 Clarence Street Sydney NSW 2000
STH SILVER THOMAS HANLEY 3 Clewley Street Glen Iris Victoria 3146



Project: **HORNSBY KU-RING-GAI HOSPITAL - STAGE 2**
 Palmerston Road, Hornsby NSW 2077
 Sheet Subject: **SITE WORKS PLAN SHEET 2 OF 4**

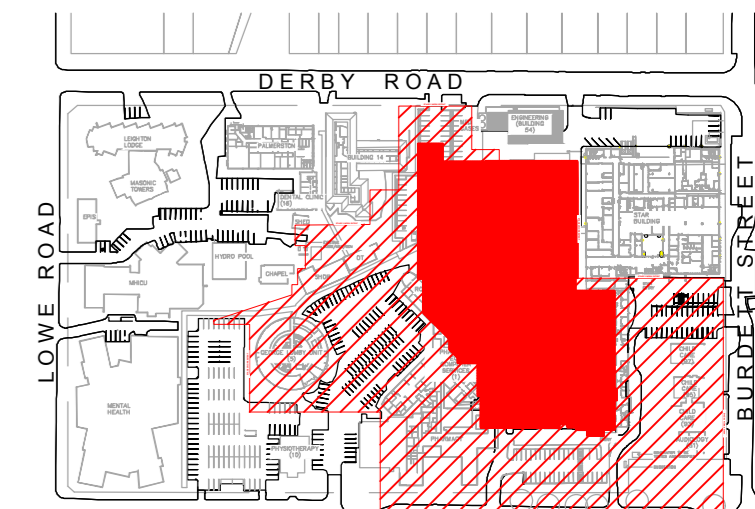

MHC10

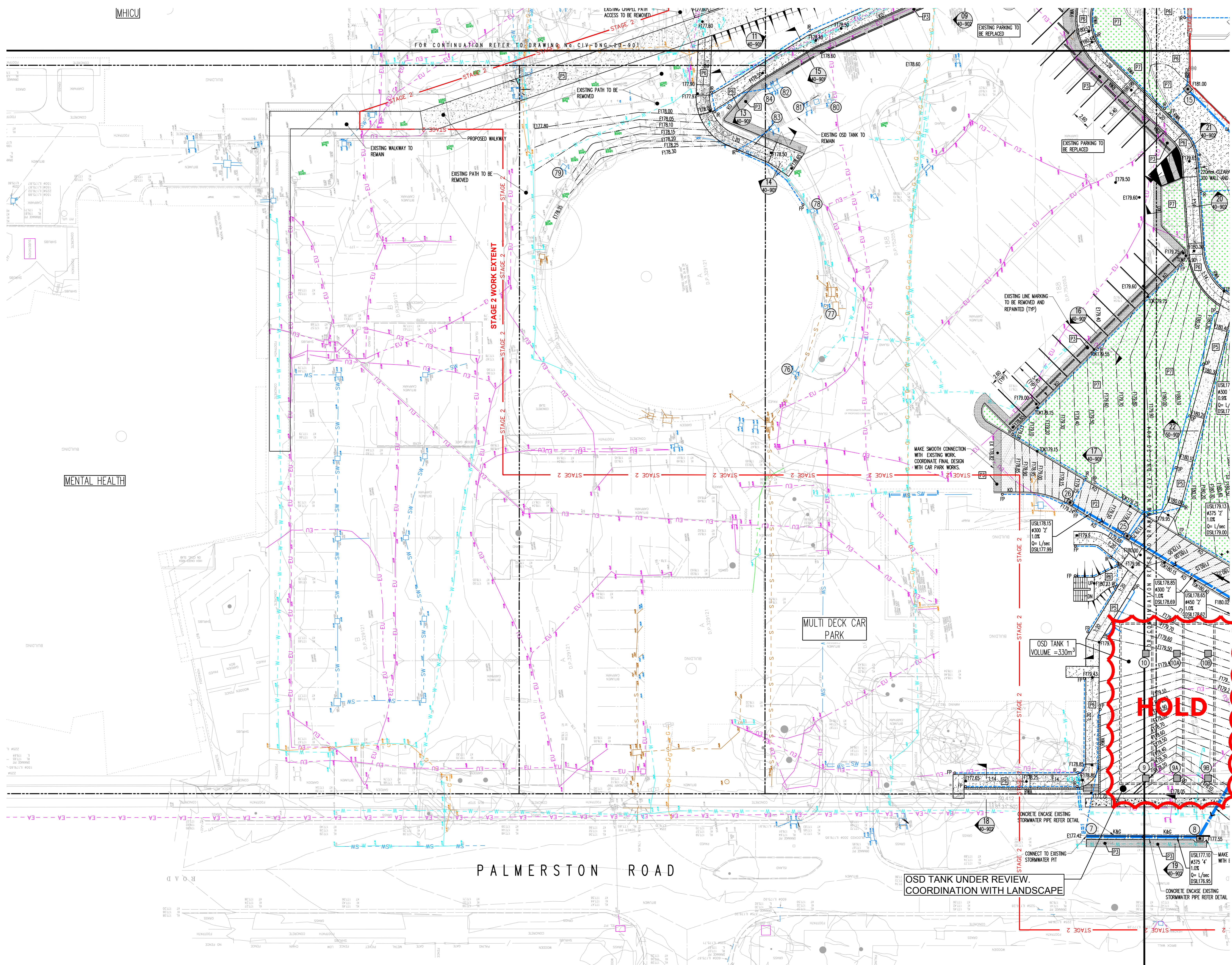

PAVEMENT LEGEND

- PAVING - 1x10⁶**
 - F1 200mm Thickness concrete (f_c=32MPa) with 3.82 fabric (40 top cover) on 100mm Compacted thickness fine crushed rock (D0820) on 400mm 6% lime stabilised existing subgrade
- ROAD PAVEMENT ASPHALT 1 x 10⁶**
 - F2 50mm Thickness asphalt concrete (AC10) on 100mm Compacted thickness fine crushed rock (D0820) on 300mm Compacted thickness fine crushed rock (D0540) on Minimum CBR 3% (due to lime stabilise subgrade to increase CBR)
- ASPHALT CONNECTION TO EXISTING - 1x10⁶**
 - F3 50mm Existing asphalt to be milled and remove the required depth basecourse materials and place 50mm Thickness asphalt concrete (AC10) on 100mm Compacted thickness fine crushed rock (D0820) on 300mm Compacted thickness fine crushed rock (D0540) on 400mm 6% lime stabilised existing subgrade
- DRIVEWAY TO HORNSBY COUNCIL REQUIREMENTS - 1x10⁶**
 - F4 200mm Thickness concrete (f_c=20MPa) with 2 layers of 3.82 fabric (40 cover) on 100mm Compacted thickness fine crushed rock (D0820) on 400mm 6% lime stabilised existing subgrade
- CONCRETE SLAB**
 - F5 Refer structural drawing
- FOOTPATH - PEDESTRIAN**
 - F6 Finish to Landscape Architect specification on 120mm Thickness concrete (f_c=20MPa) with expansion joints at max.0m centres and weakened plane joints at max 1.5m centres on 3.72 fabric (40 cover) on 50mm Sand bedding
- LANDSCAPE**
 - F7 Disturbed works to be restored with Landscaping
- GRAVEL**
 - F8 150mm Thickness decomposed granite to Landscape Architect specification on 100mm Compacted thickness fine crushed rock (D0820) on 400mm 6% lime stabilised existing subgrade
- COUNCIL PATH**
 - F9 120mm Thickness concrete (f_c=20MPa) with expansion joints at max.0m centres and weakened plane joints at max 1.5m centres on 3.72 fabric (40 cover) on 50mm Sand bedding

PIT SCHEDULE

Note: Grate size does not necessarily reflect pit size, refer pit type details, shown on detail sheets - **DNG-30-001**. Final pit size dimensions to be comply with AS3500.

Type	Description	Cover (Clear Opening)	Number
A	Kerb inlet pit 1800 inlet	600 x 900 Class D galvanised mild steel grate hinged to frame	28,23,54, 35,06,08
B	Surface inlet pit	900x900 Class C galvanised HEEL GUARD mild steel grate hinged to frame with Envirogrid basket	38,38,40,50
		900x600 Class C galvanised HEEL GUARD mild steel grate hinged to frame	42,60
		1200x1200 Class D galvanised mild steel grate hinged to frame	41,43, 54,75
Junction pit	900 x 900 Class B power accepting grate	41,16	
Enviropods pit	900 x 900 Class C galvanised mild steel grate hinged to frame with Enviropod basket	11,12,13,16, 22,24,25, 26,27,28,30, 66,67,68,69	
		Existing pit to be reconstructed to suit new works. Grate to be replaced with Class C galvanised HEEL GUARD mild steel grate hinged to frame	18,19,23,61, 25,70,71,76, 77,78,87,88, 102,103,104, 117
E	Existing pit to remain	21,22,62,63, 64,72,80,81, 82,83,84,86, 86,88,90,91, 92,93,94,95, 96,97,98,99, 105,106,107, 108,109,110	
		36,38,39,39, 40,104, 101,101,100, 101,01	
F	OSD Access	1200 X 1200 Class C galvanised mild steel grate hinged to frame	34,35,36,37, 48,49,50,51, 62,61,112, 113,114,115, 116,117,118, 119,120, 121,122
		Existing pit to be demolished and removed.	

Rev	Description	Eng	Draft	Date
A	ISSUE FOR CONSTRUCTION	SH	JH	28.06.18

WATPAC Level 10, 155 Clarence Street Sydney NSW 2000

STH SILVER THOMAS HANLEY 3 Cleverly Street Glen Iris Victoria 3146

Mechanical & Electrical
NSW
Hydraulic & Fire
NSW
Civil

NSW Health Infrastructure
Level 8, 77 Pacific Highway, North Sydney NSW 2060

Project
HORNSBY KU-RING-GAI HOSPITAL - STAGE 2
Palmerston Road, Hornsby NSW 2077

Sheet Subject
SITE WORKS PLAN SHEET 3 OF 4

Civil Engineer
TTW Taylor Thomson Whitting
612 9439 7288 | 48 Chandos Street St Leonards NSW 2065

Scale: A0
1:200
Drawn: JH
Authorised: [Signature]
Job No: Drawing No: Revision: [Signature]

161607 CIV-DNG-20-903 A

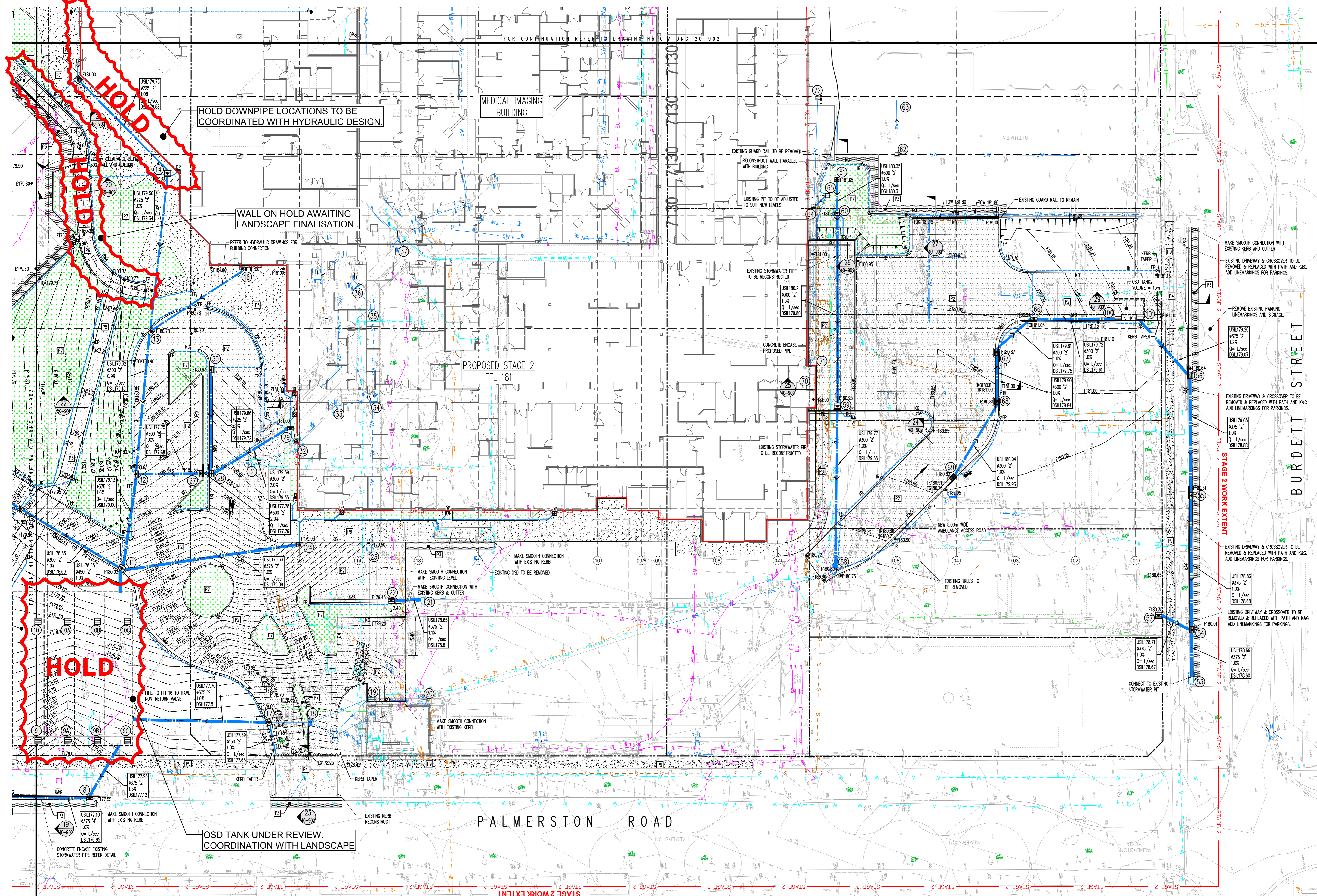
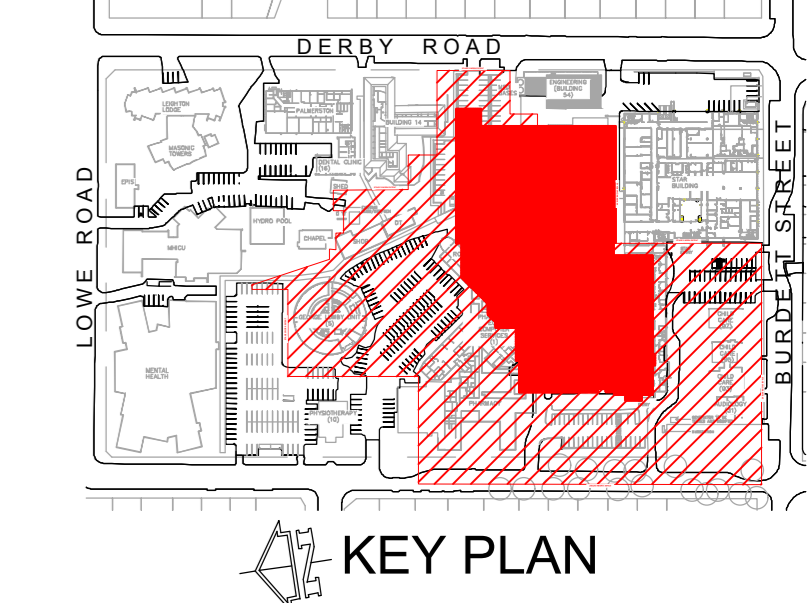

PAVEMENT LEGEND

- PAVING - 1x10⁶**
 - [P1] 200mm Thickness concrete (f_c=32MPa) with 5.82 fabric (40 lap cover) on 100mm Compacted thickness fine crushed rock (DGS20) on 400mm 6% fine stabilised existing subgrade
- ROAD PAVEMENT ASPHALT 1 x 10⁶**
 - [P2] 50mm Thickness asphaltic concrete (AC10) on 100mm Compacted thickness fine crushed rock (DGS20) on 300mm Compacted thickness fine crushed rock (DGS40) on Minimum CBR 3% (allow to time stabilise subgrade to increase CBR)
- ASPHALT CONNECTION TO EXISTING - 1x10⁶**
 - [P3] 50mm Existing asphalt to be milled and remove the required depth basecourse materials and place 50mm Thickness asphaltic concrete (AC10) on 100mm Compacted thickness fine crushed rock (DGS20) on 300mm Compacted thickness fine crushed rock (DGS40) on 400mm 6% fine stabilised existing subgrade
- DRIVEWAY TO HORNSBY COUNCIL REQUIREMENTS - 1x10⁶**
 - [P4] 200mm Thickness concrete (f_c=32MPa) with 2 layers of 5.82 fabric(40 cover) on 100mm Compacted thickness fine crushed rock (DGS20) on 400mm 6% fine stabilised existing subgrade
- CONCRETE SLAB**
 - [P5] Refer structural drawing
- FOOTPATH - PEDESTRIAN**
 - [P6] Finish to Landscape Architect specification on 120mm Thickness concrete (f_c=32MPa) with expansion joints at max 1.5m centres and weakened plane joints at max 1.5m centres on 5.72 fabric (40 cover) on 50mm Sand bedding
- LANDSCAPE**
 - [P7] Disturbed works to be restored with Landscaping
- GRAVEL**
 - [P8] 150mm Thickness decomposed granite to Landscape Architect specification on 100mm Compacted thickness fine crushed rock (DGS20) on 400mm 6% fine stabilised existing subgrade
- COUNCIL PATH**
 - [P9] 120mm Thickness concrete (f_c=32MPa) with expansion joints at max 1.5m centres and weakened plane joints at max 1.5m centres on 5.72 fabric (40 cover) on 50mm Sand bedding

PIT SCHEDULE

Note: Grate size does not necessarily reflect pit size, refer pit type details, shown on detail sheets - DNG-30-901

Type	Description	Cover (Clear Opening)	Number
A	Kerb inlet pit 1800 inlet	600 x 900 Class D galvanised mild steel grate hinged to frame	13,354, 55,56,58
B	Surface inlet pit	900x900 Class C galvanised HEEL GUARD mild steel grate hinged to frame with Envirograps basket	38,39,40,59
		900x600 Class C galvanised HEEL GUARD mild steel grate hinged to frame	42,60
		1200x1200 Class D galvanised mild steel grate hinged to frame	41,43, 74,75
	Junction pit	900 x 900 Class B power accepting pit	43,76
	Envirograps pit	900 x 900 Class C galvanised mild steel grate hinged to frame with Envirograps basket	13,23,33, 34,70,80,81, 82,84,85, 86,88,90,91, 92,93,94,95, 96,97,98,99, 100,106,107, 108,109,110
D	Existing pit to be reconstructed to suit new works. Grate to be replaced with Class C galvanised HEEL GUARD mild steel grate hinged to frame		16,70,75,87, 65,70,71,76, 77,78,87,89, 102,103,104, 117
E	Existing pit to remain		20,27,82,83, 84,70,80,81, 82,84,85, 86,88,90,91, 92,93,94,95, 96,97,98,99, 100,106,107, 108,109,110, 100,101
F	OSD Access	1200 X 1200 Class C galvanised mild steel grate hinged to frame	5,9,38,96,97, 80,10,104, 106,107,100, 100,101
	Existing pit to be demolished and removed.		9,31,32,33, 34,35,36,37, 46,49,50,51, 52,111,112, 113,114,115, 116,117,118, 119,120, 121,122

Rev	Description	Eng	Drawn	Date
A	ISSUE FOR CONSTRUCTION	KH	JH	28.06.18



Project: **HORNSBY KU-RING-GAI HOSPITAL - STAGE 2**
 Palmerston Road, Hornsby NSW 2077
 Sheet Subject: **SITE WORKS PLAN SHEET 4 OF 4**

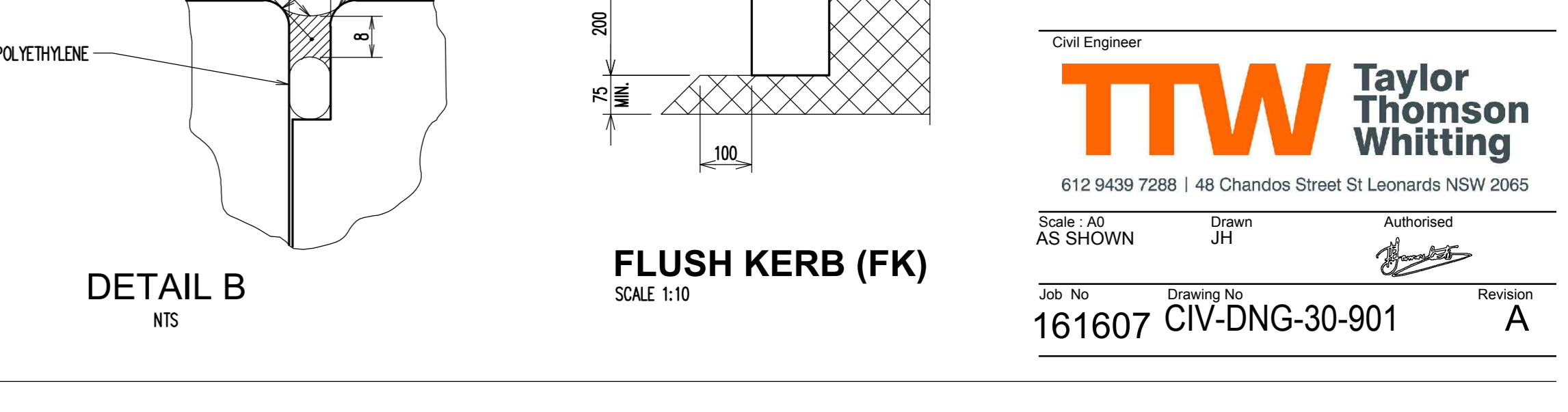
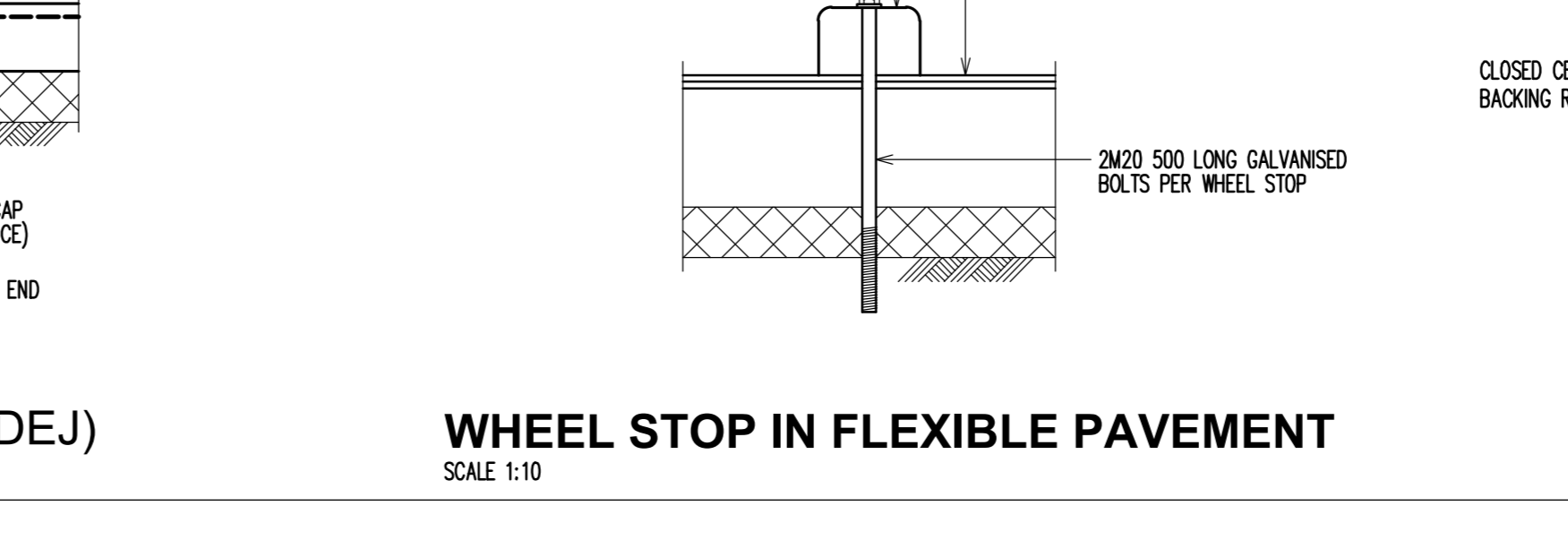
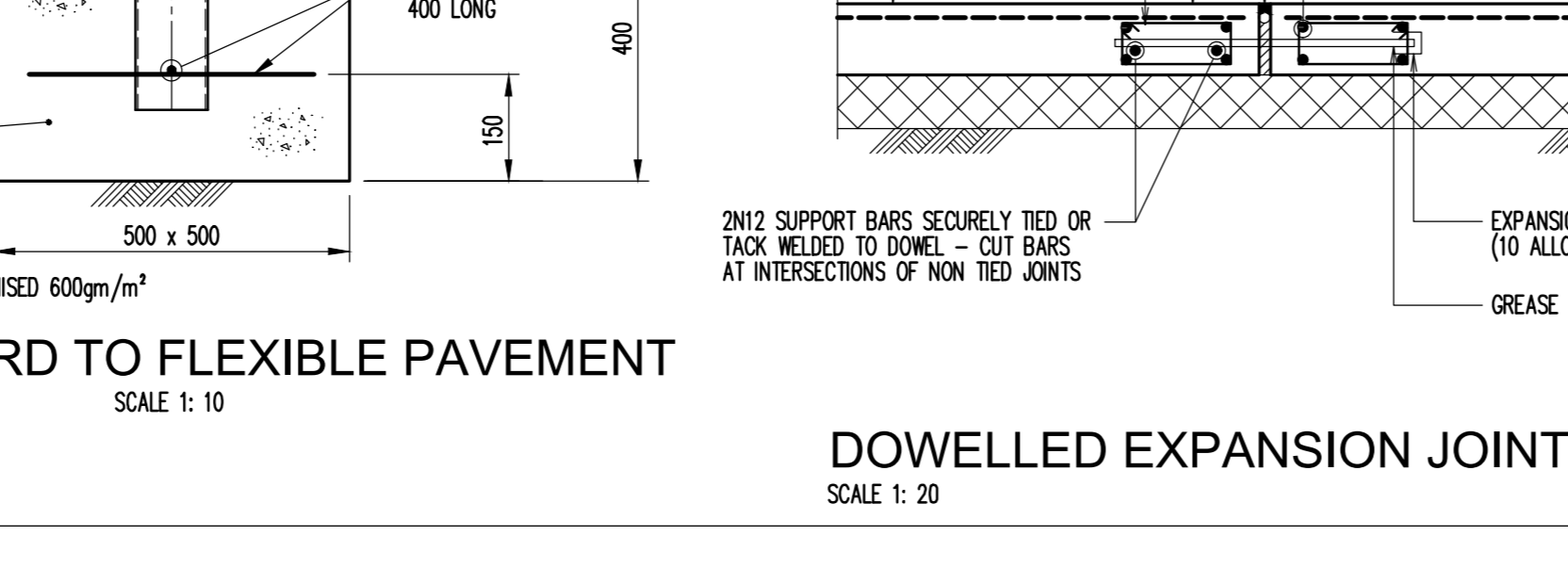
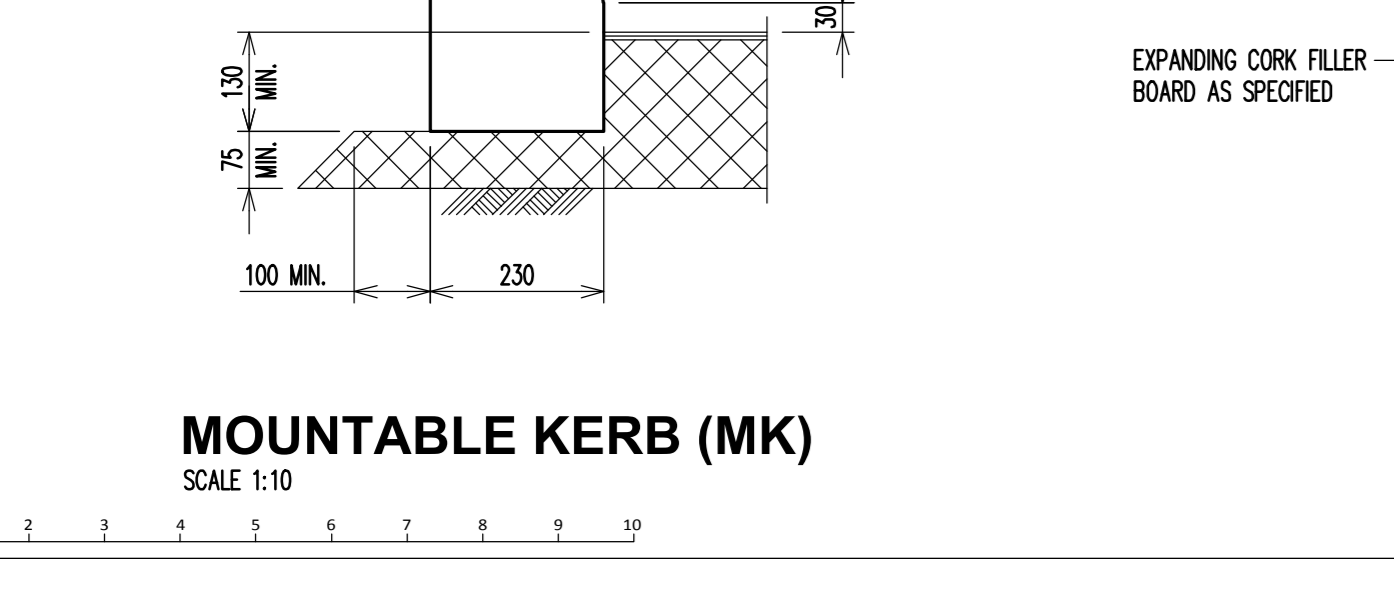
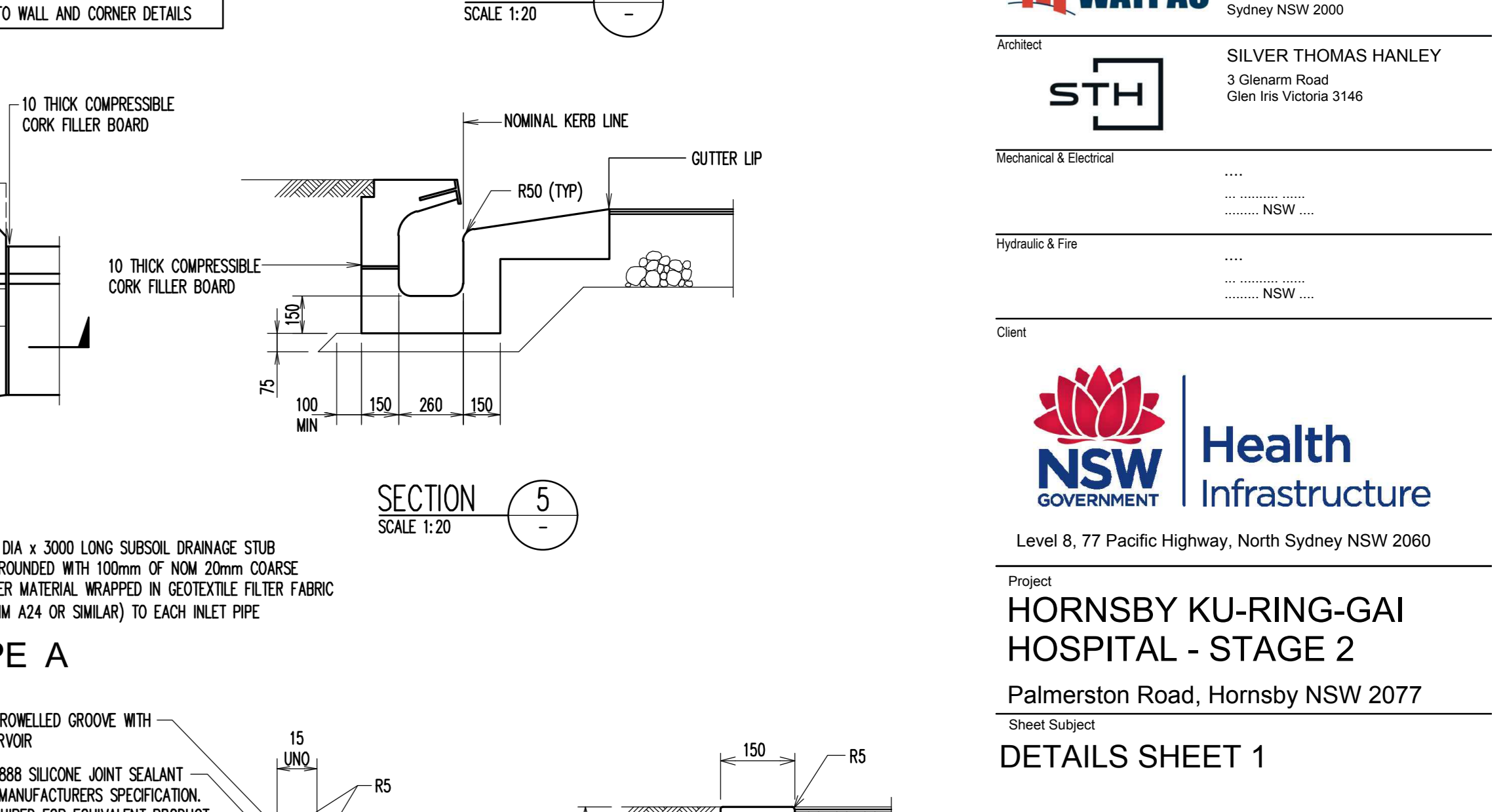
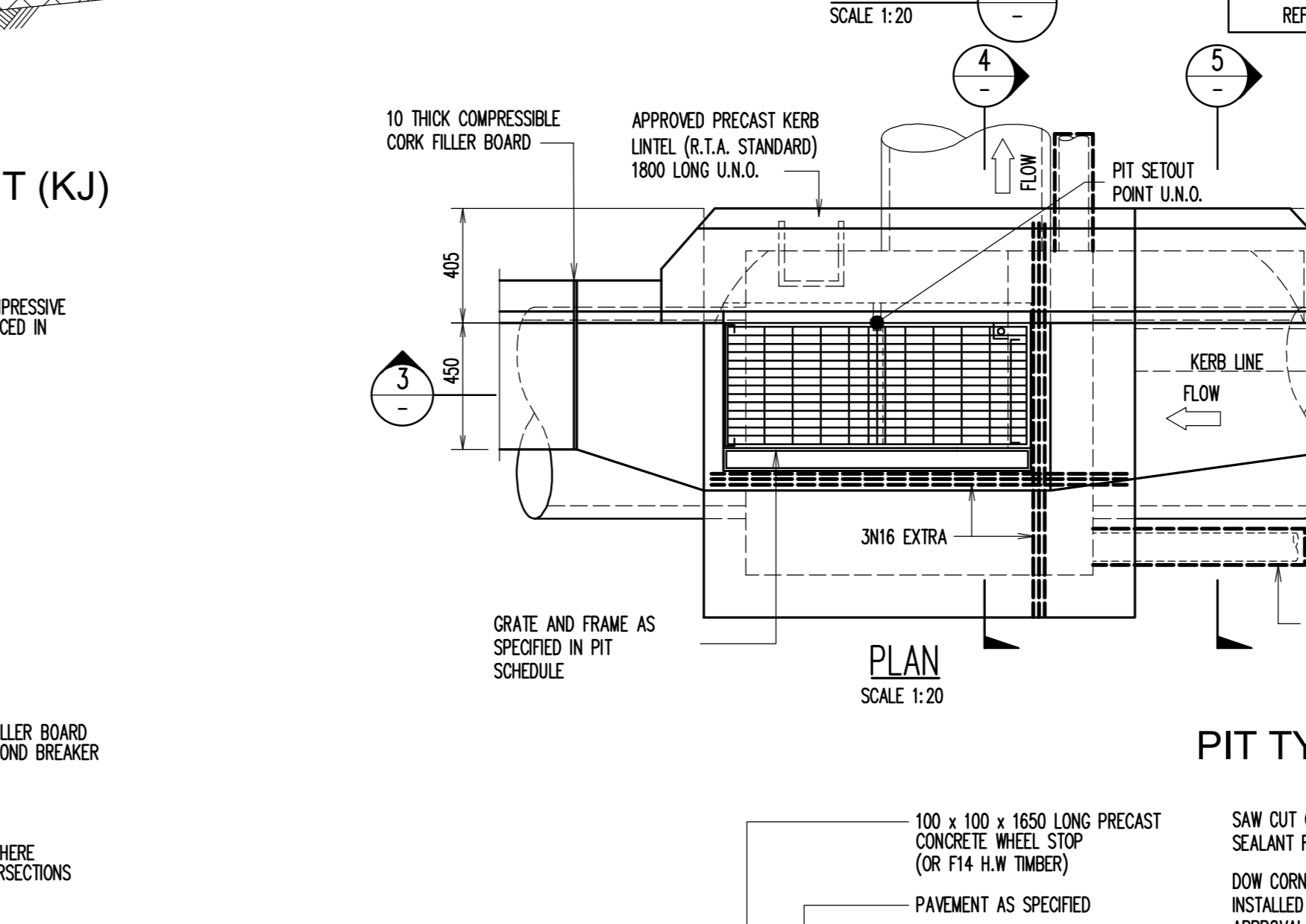
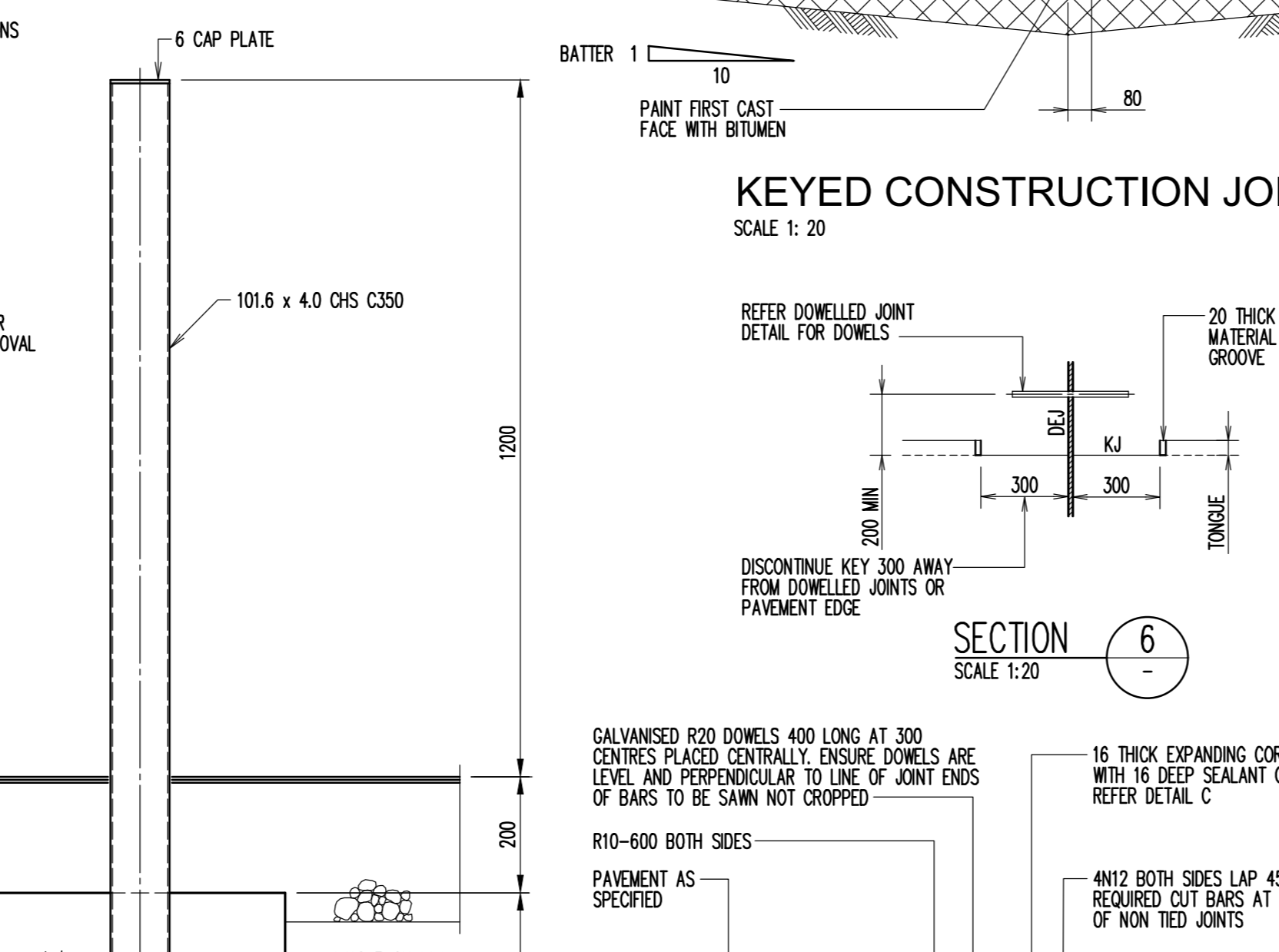
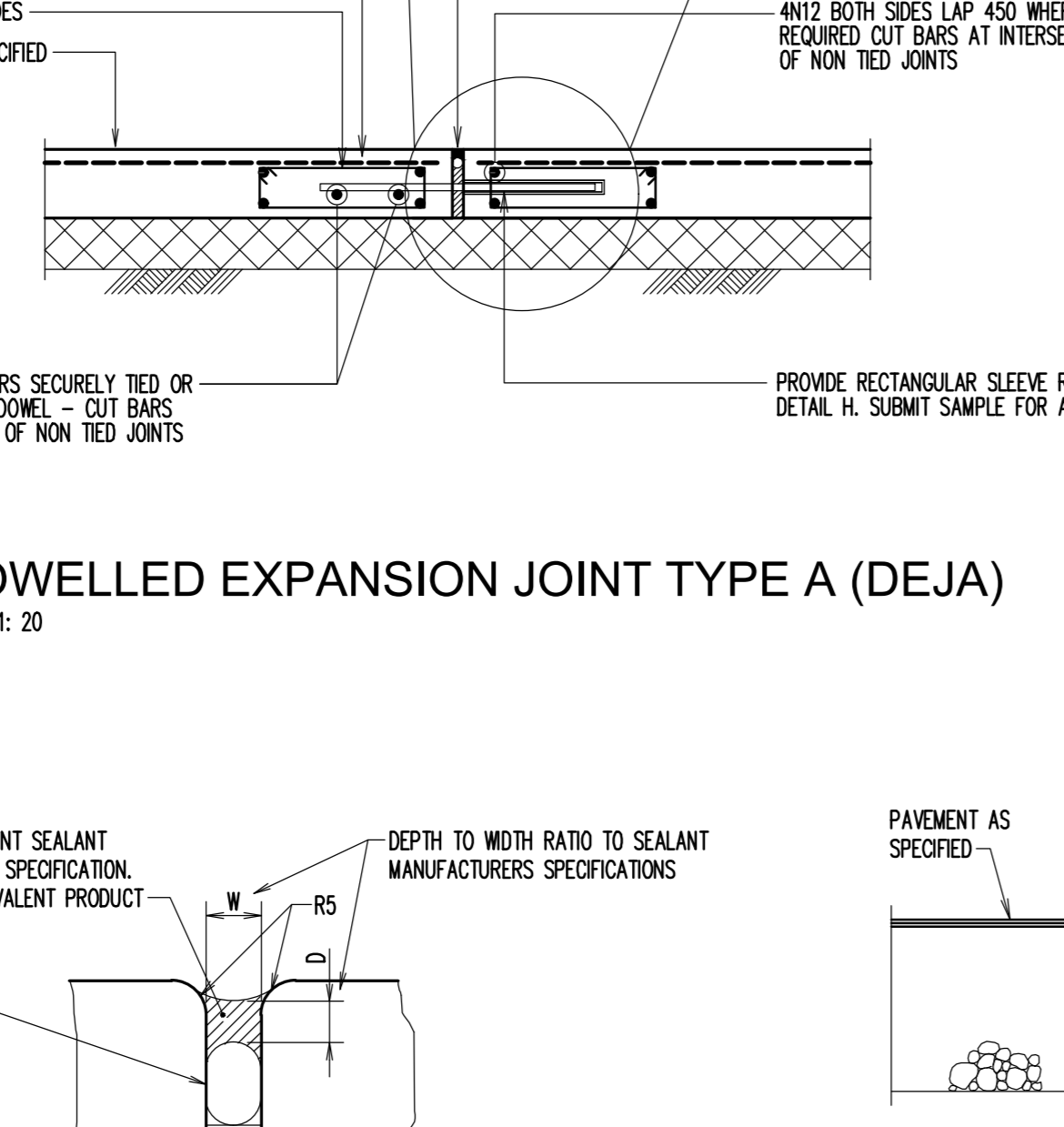
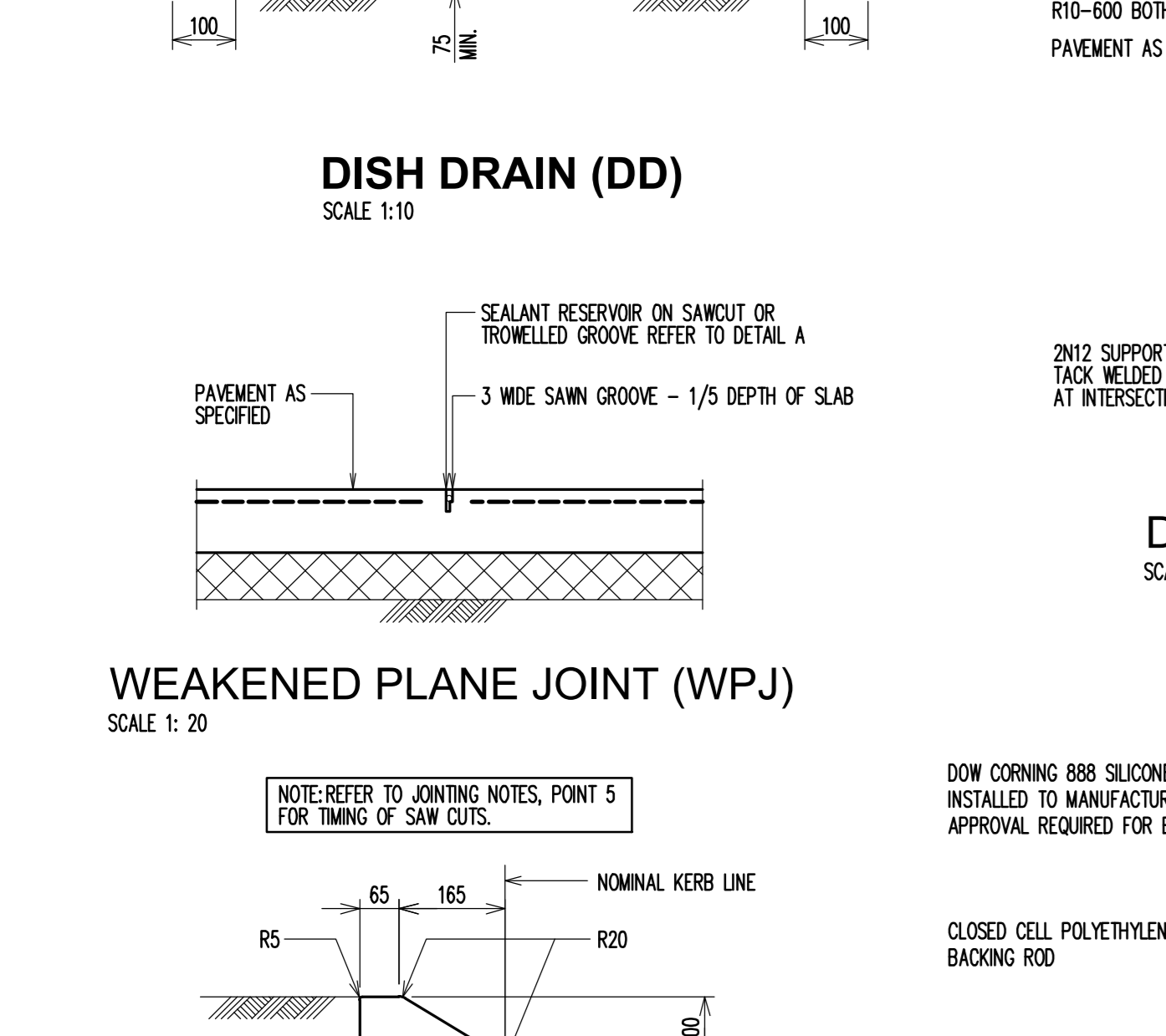
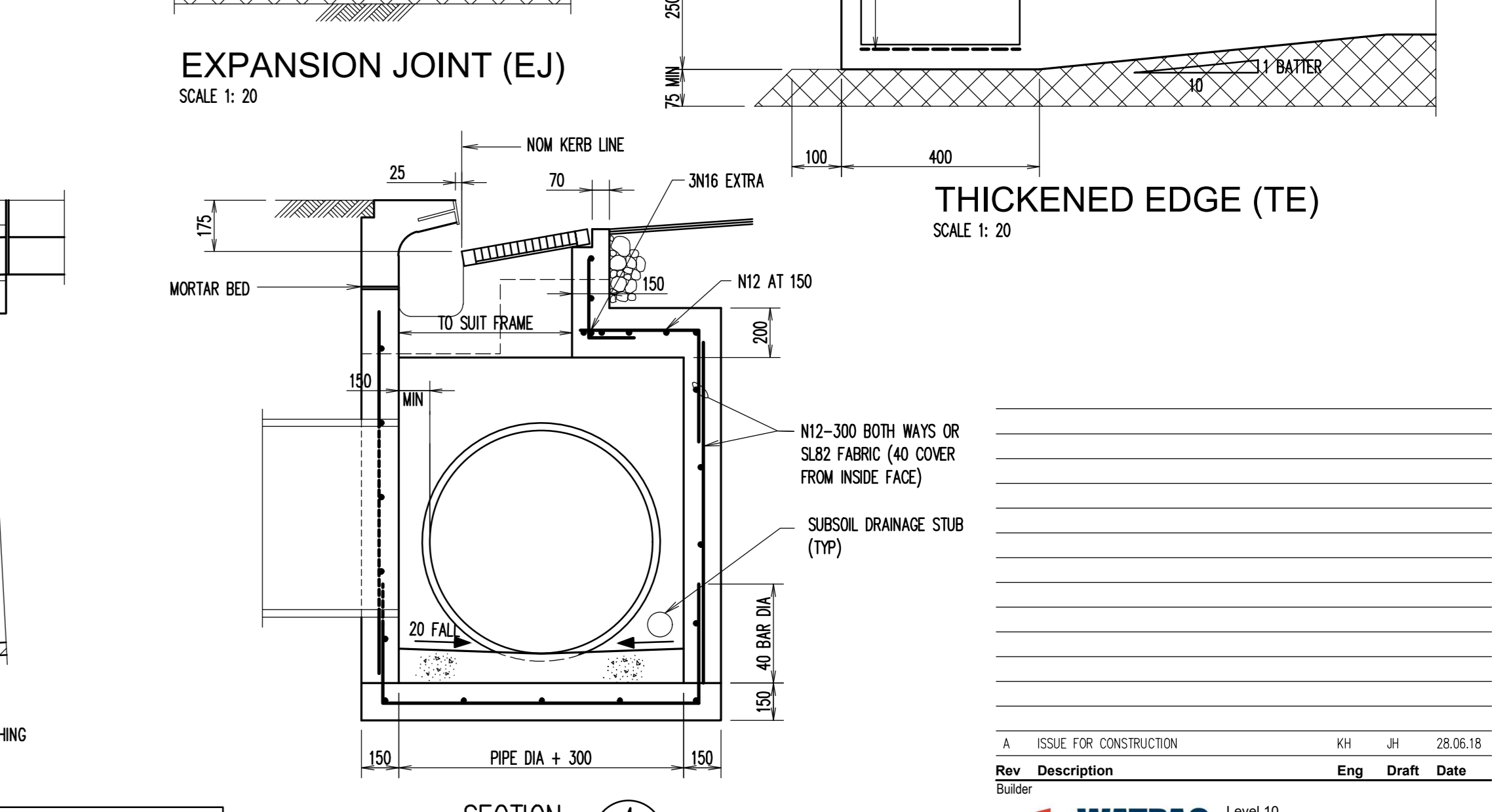
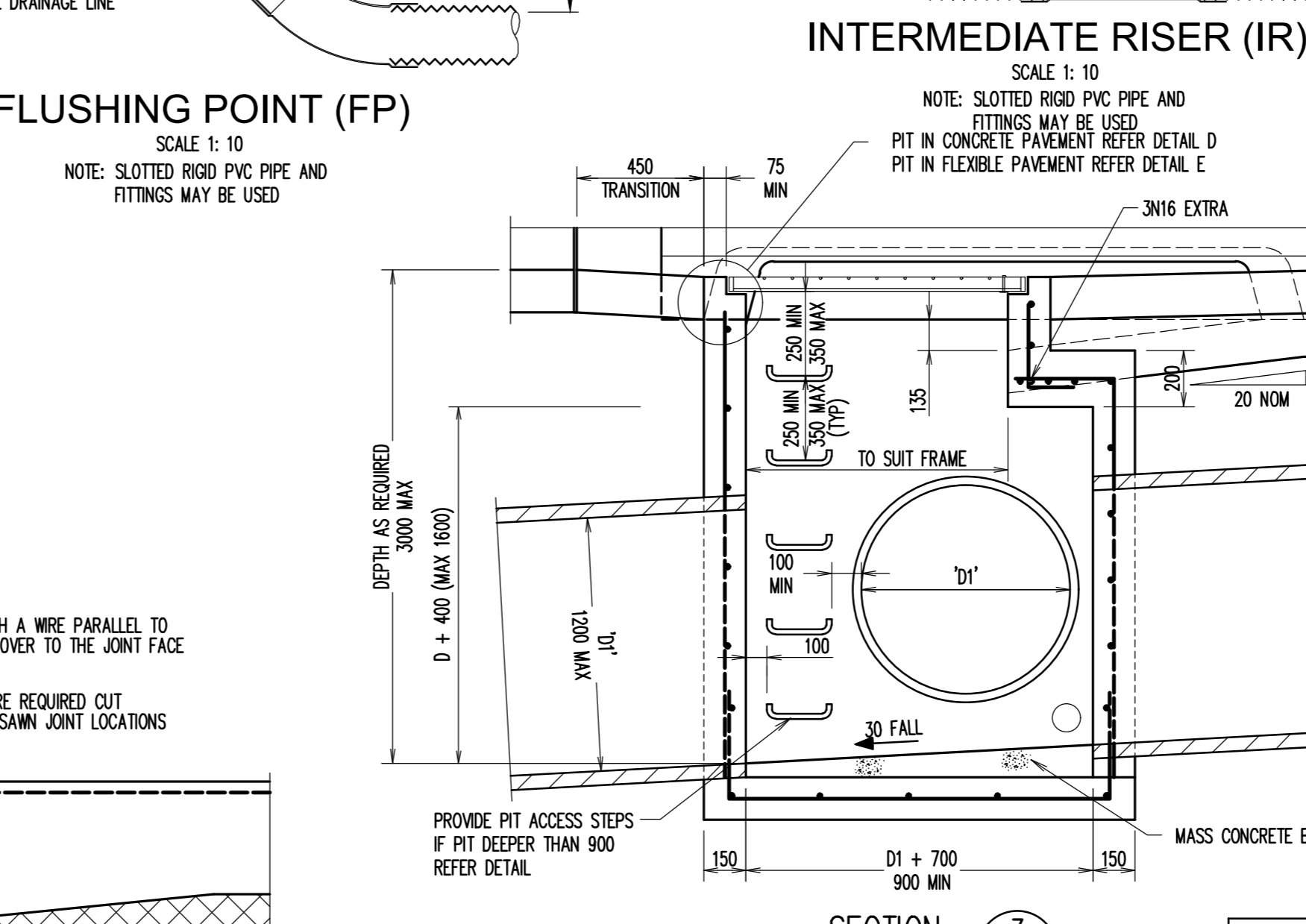
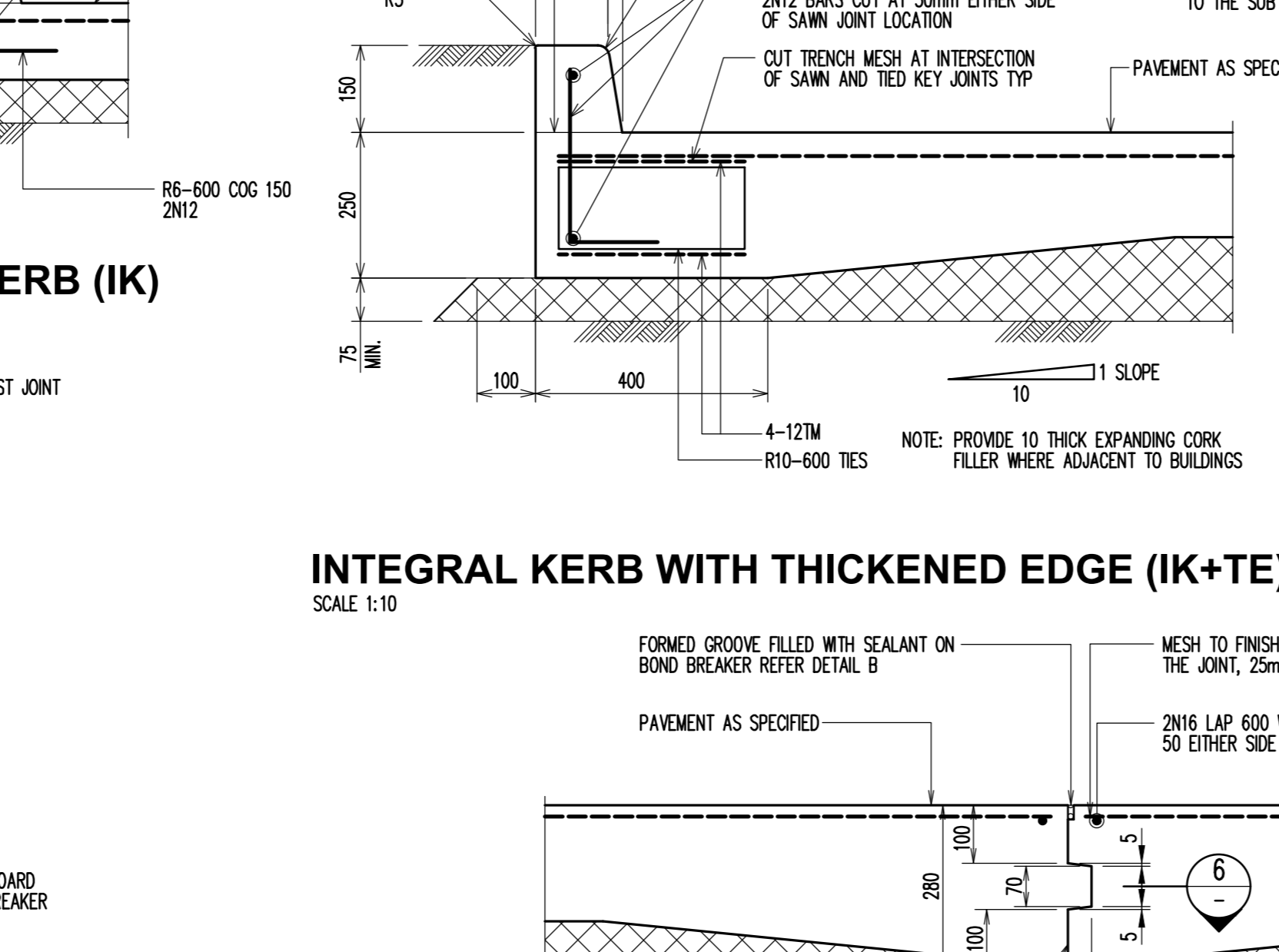
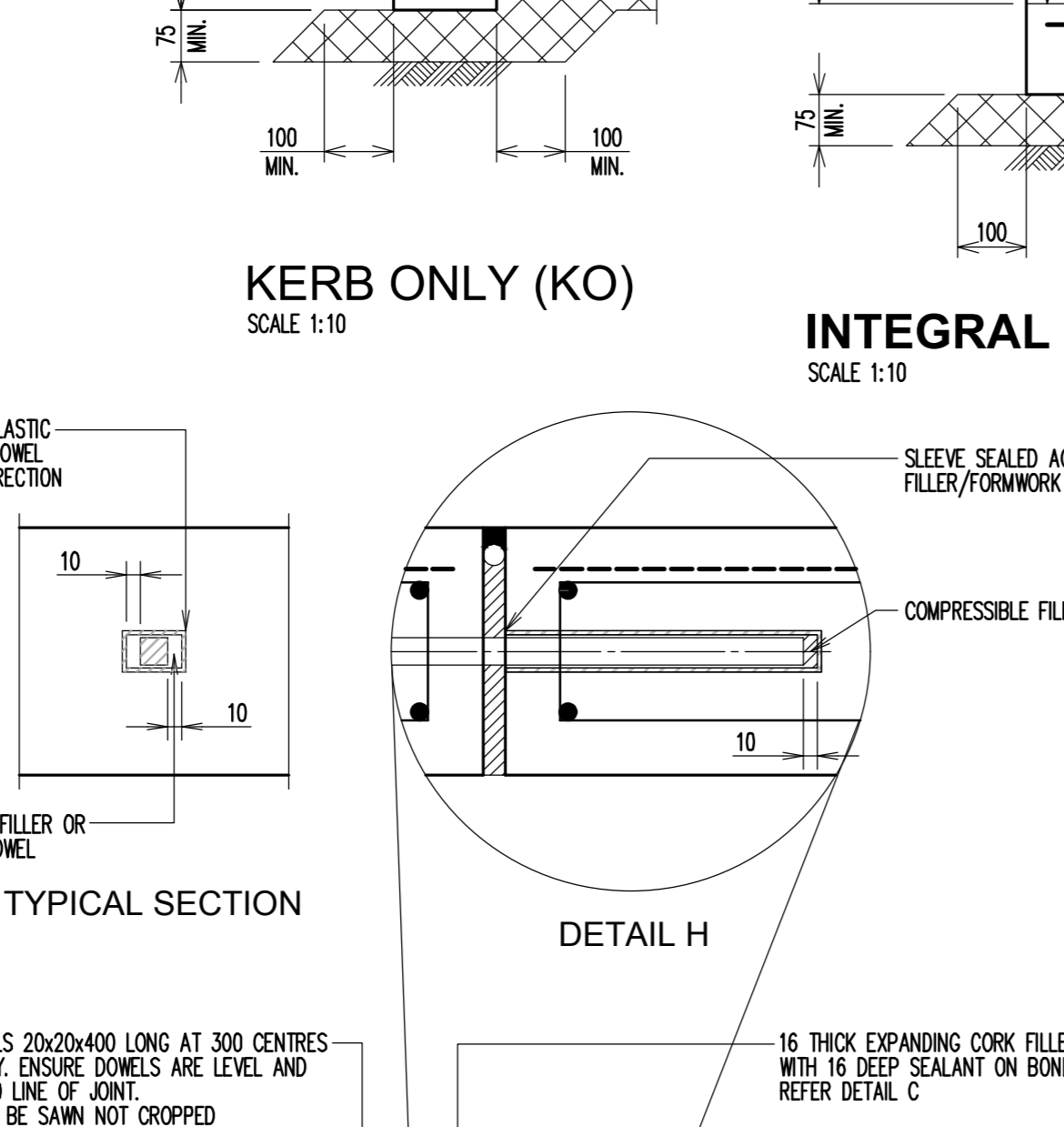
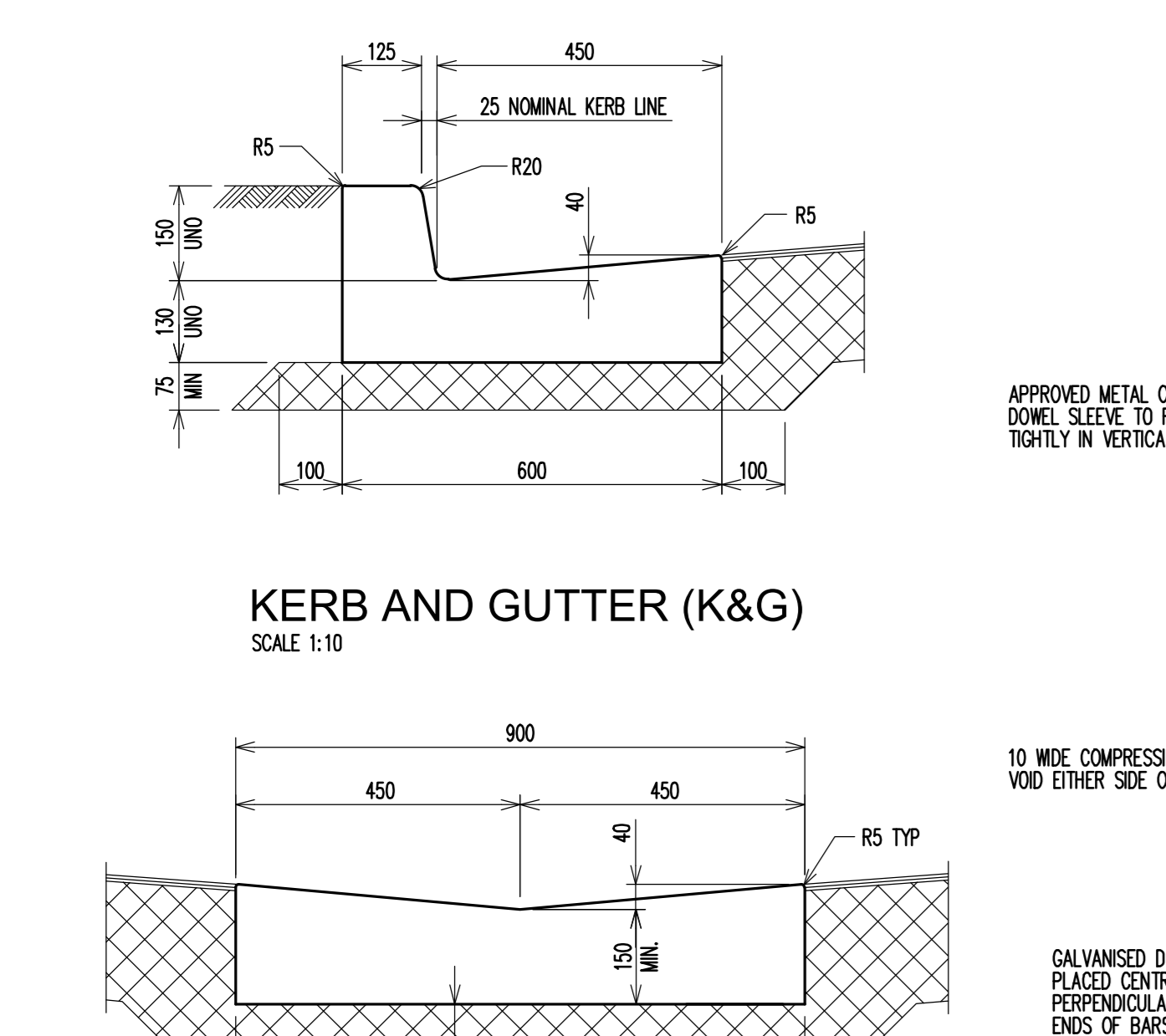
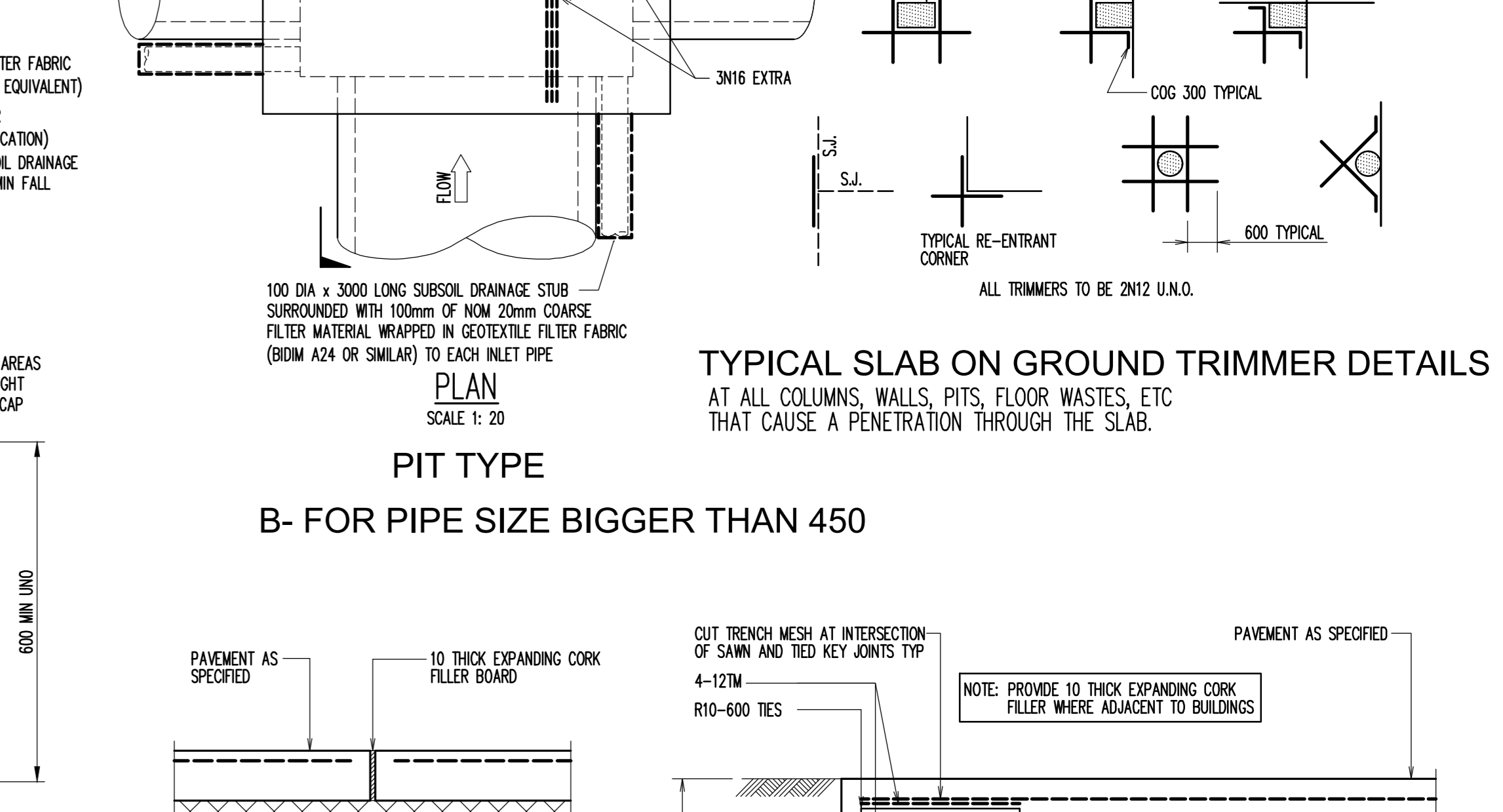
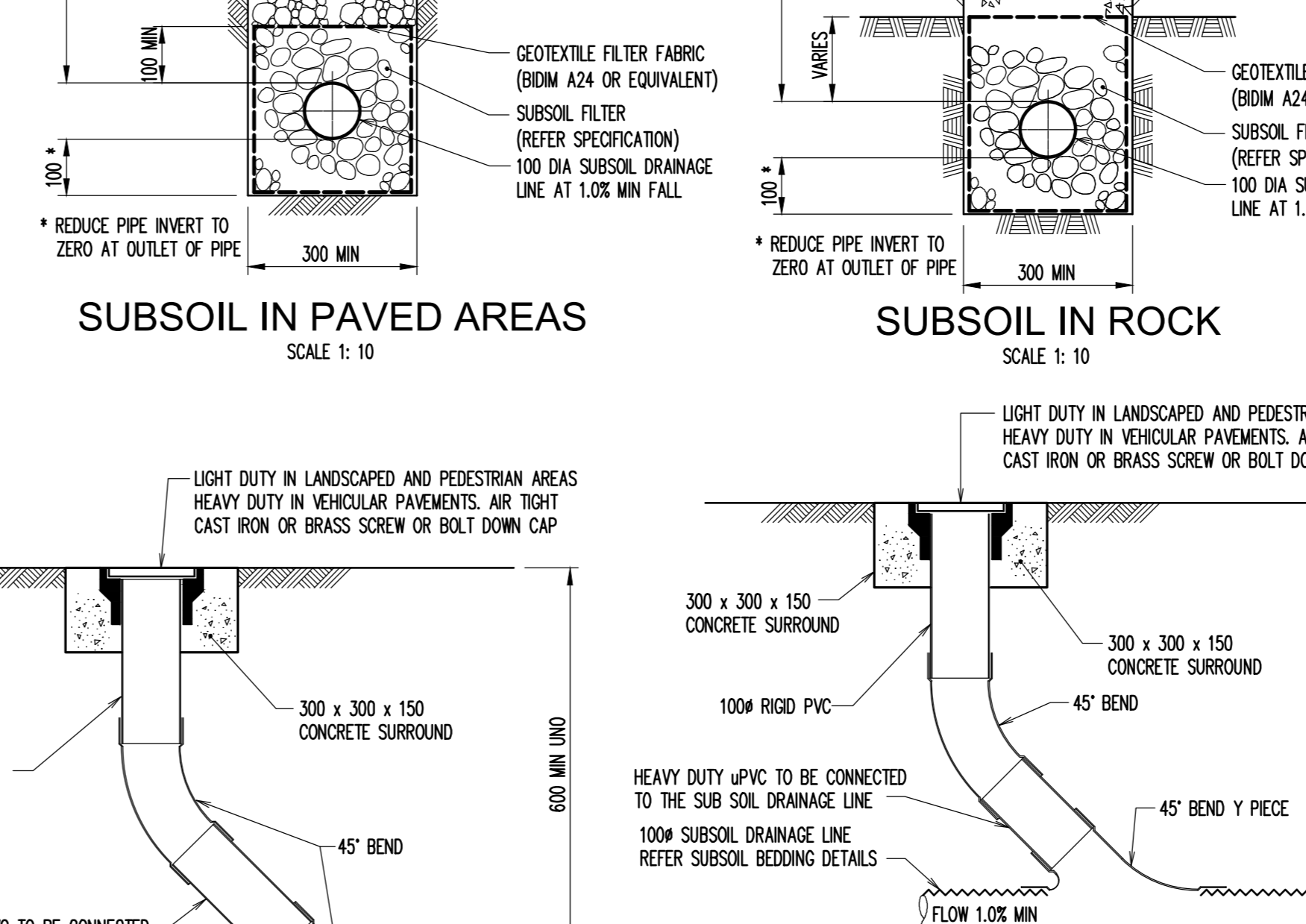
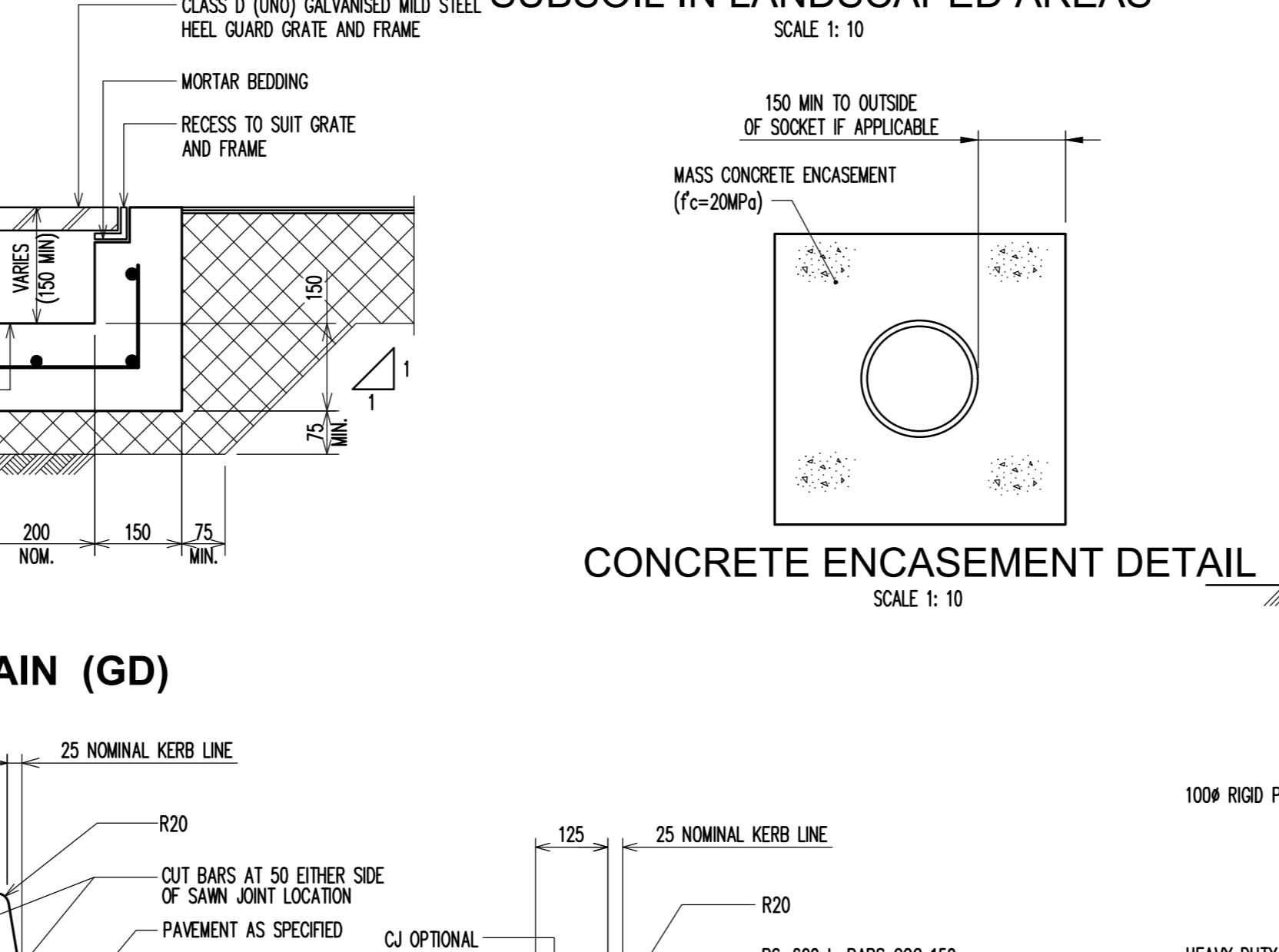
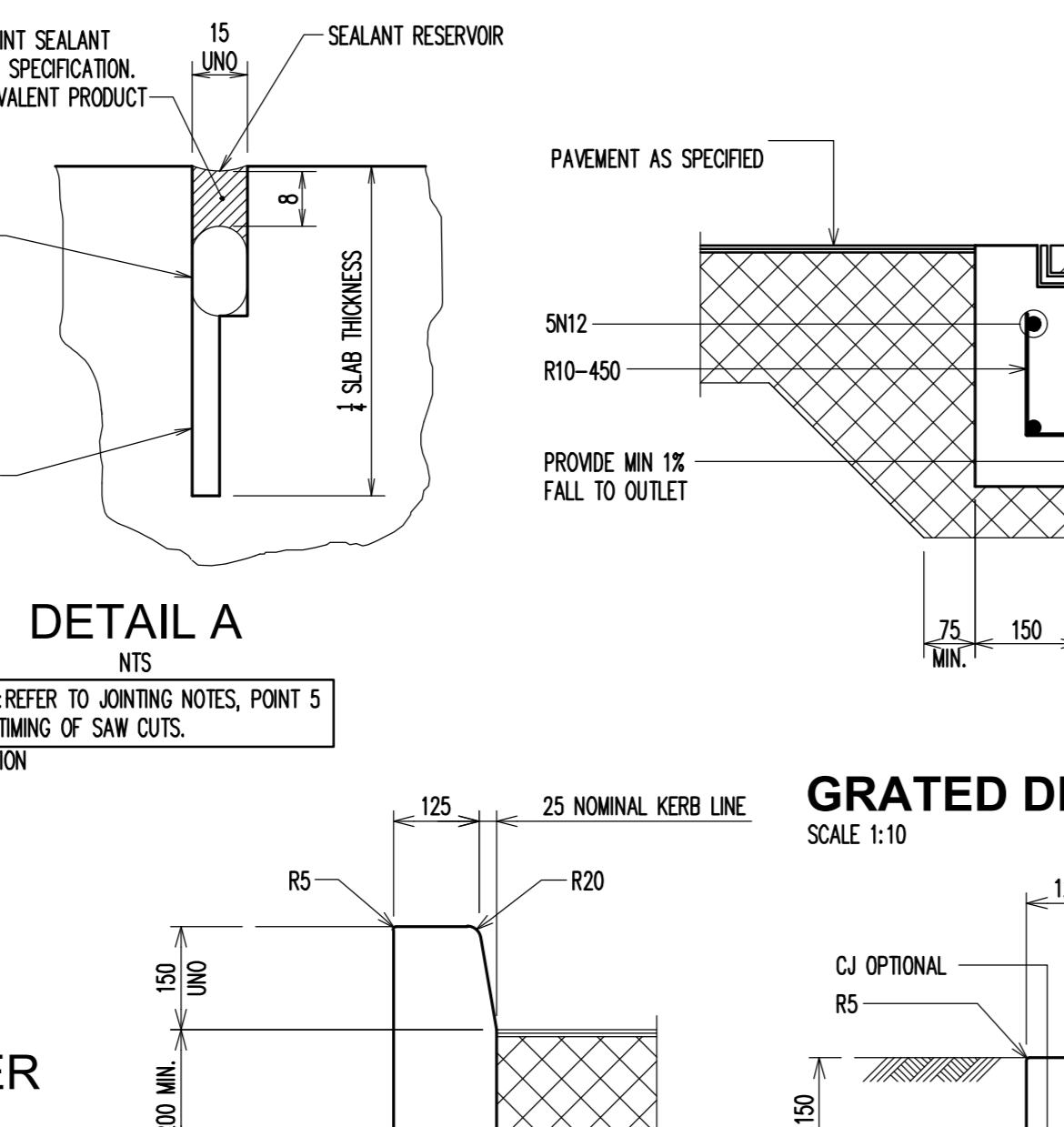
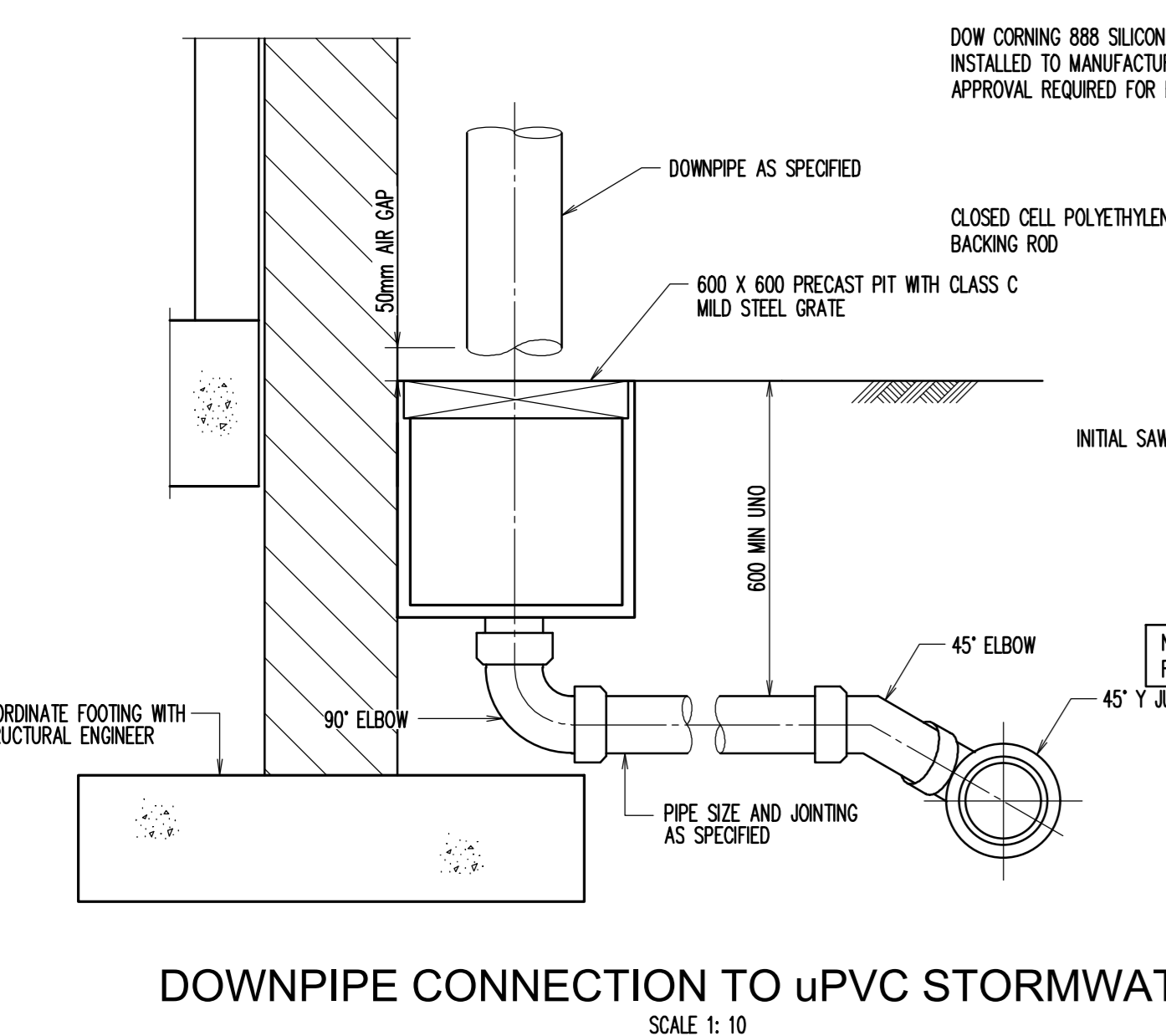
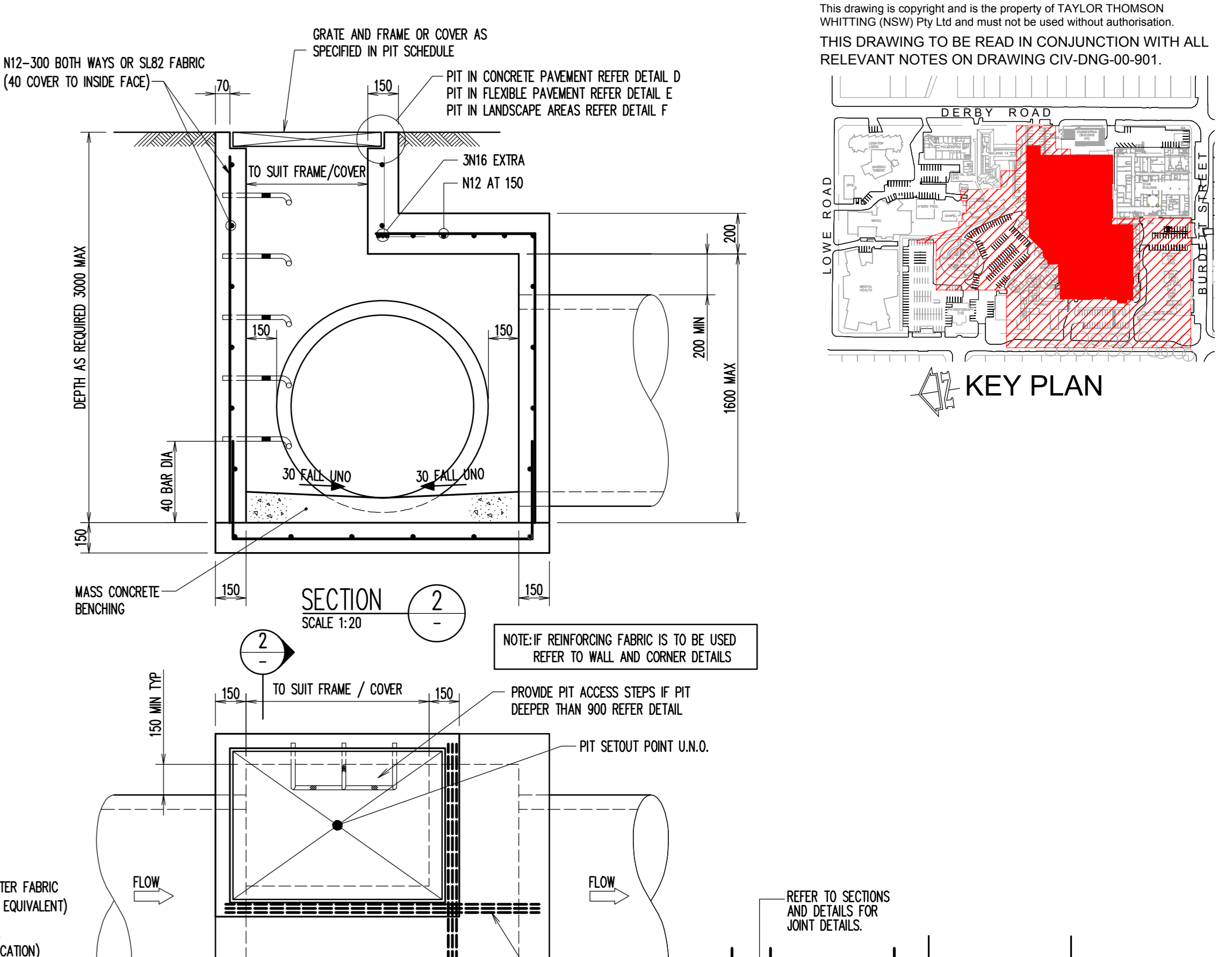
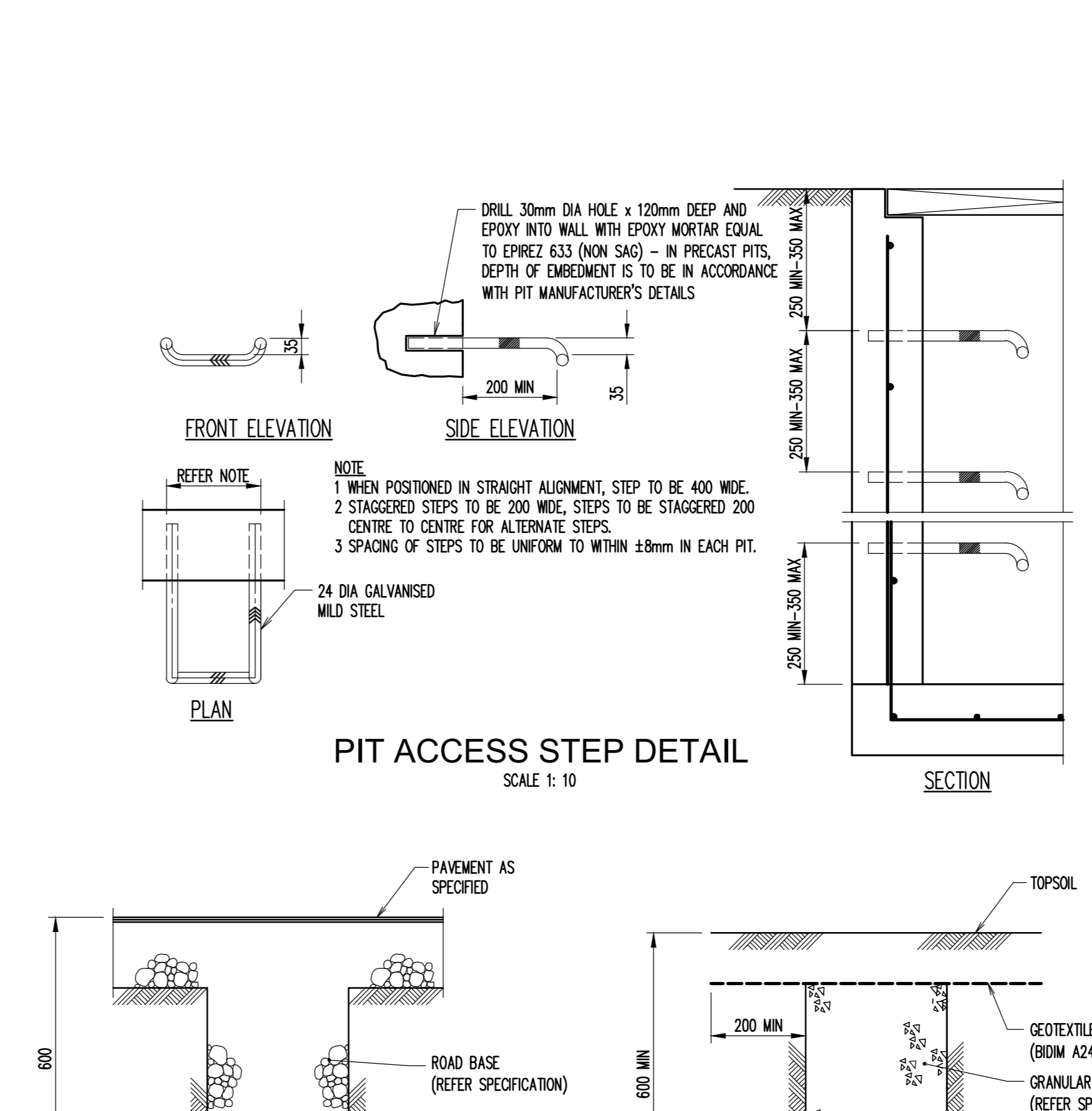
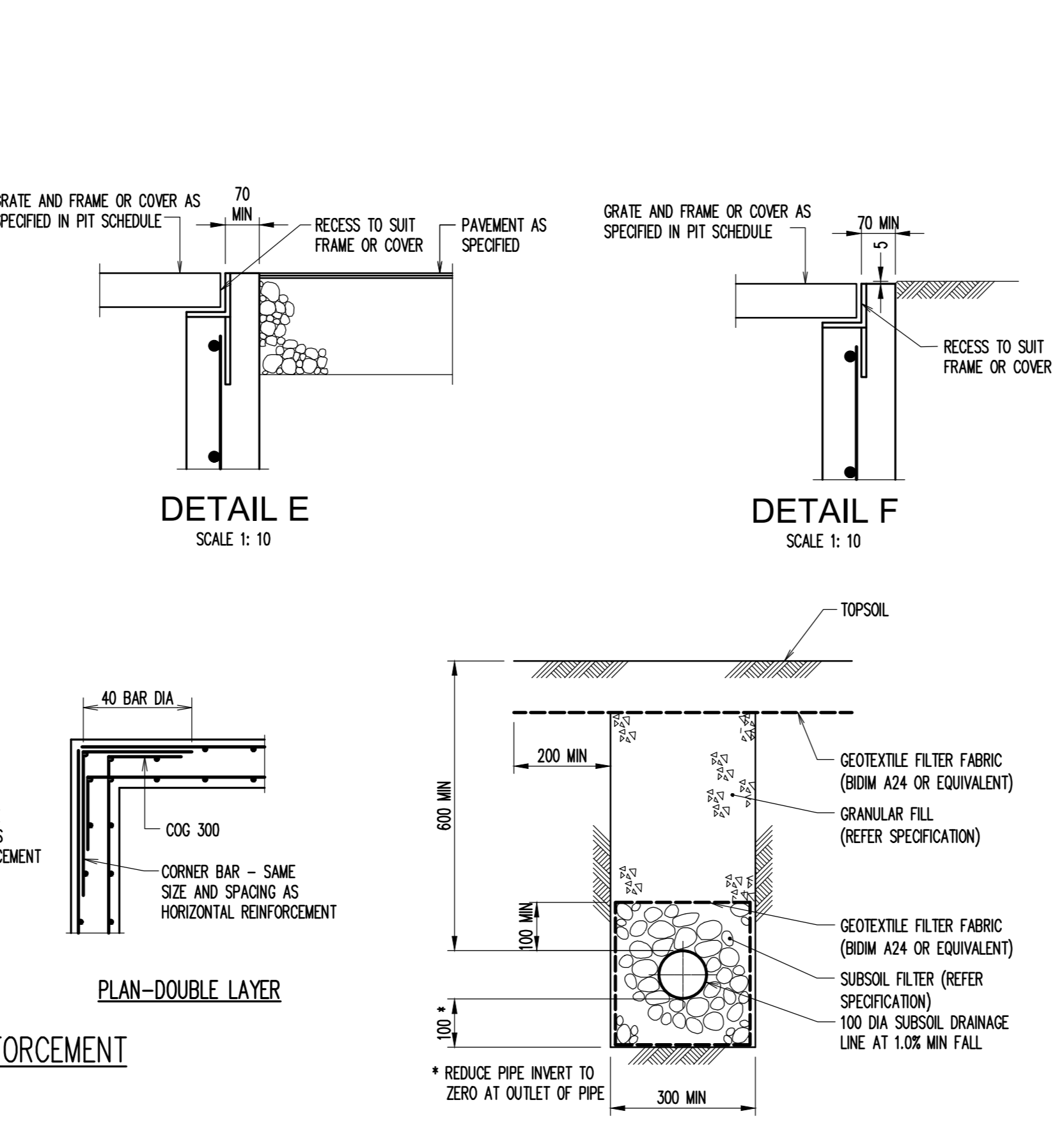
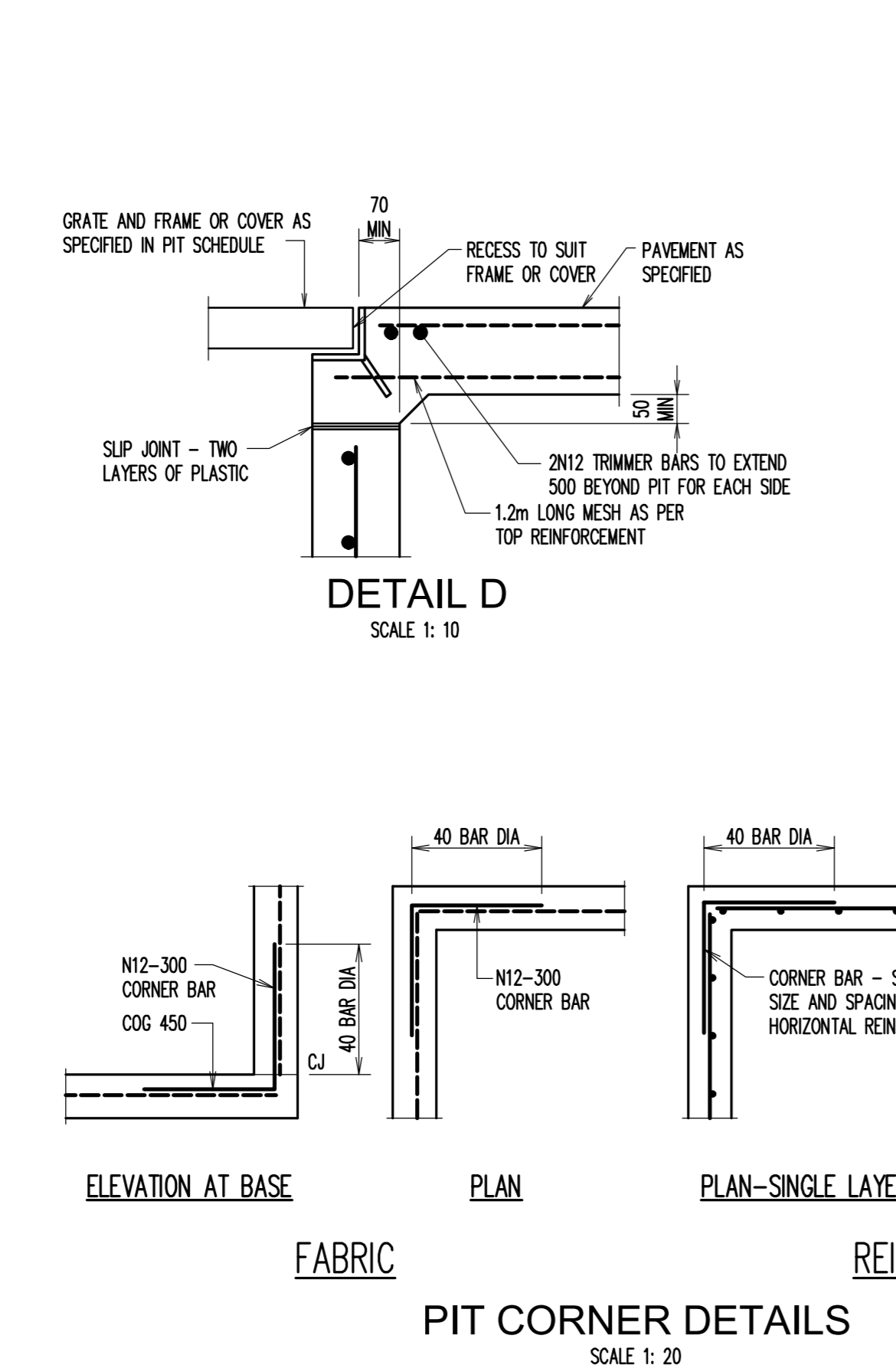
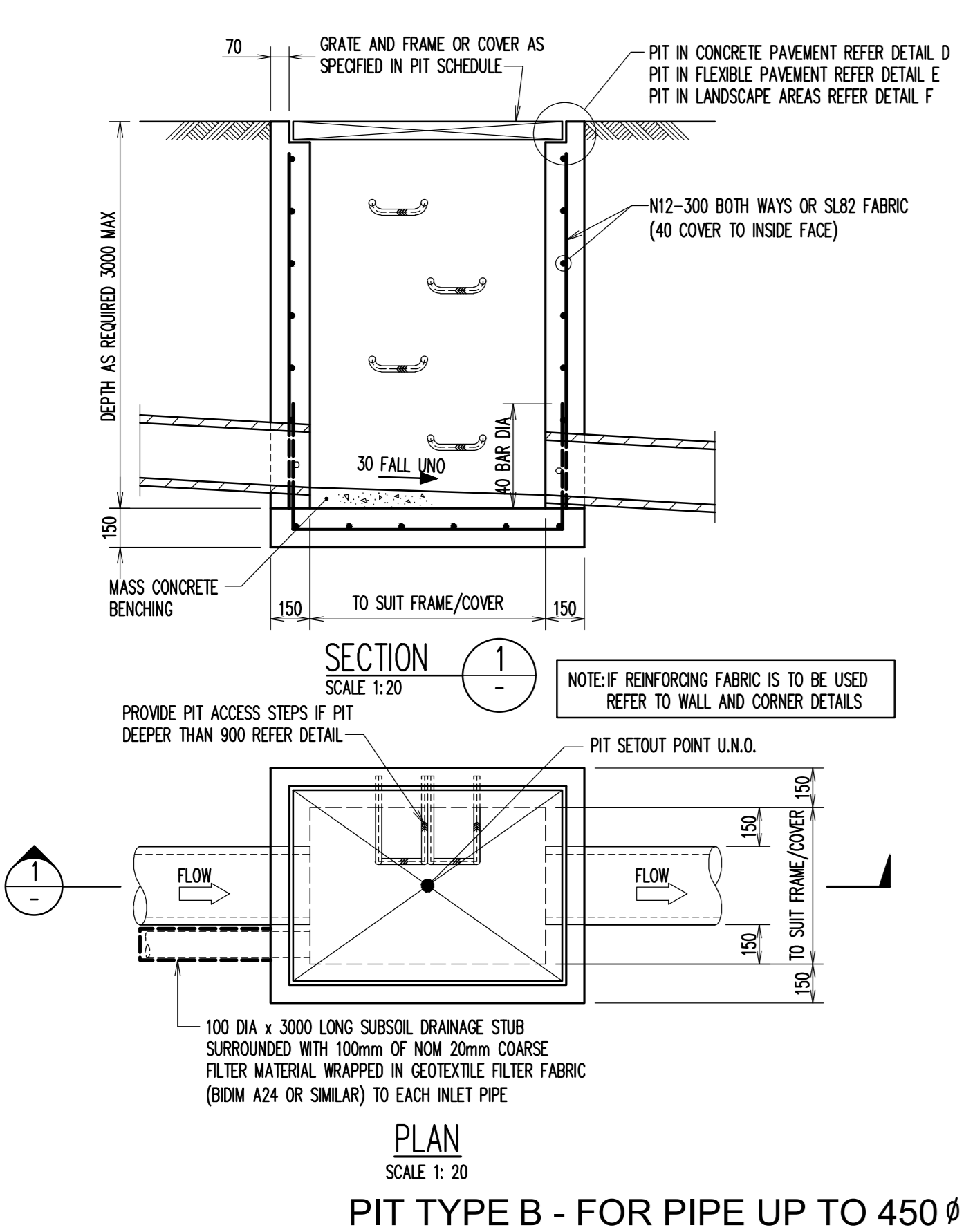
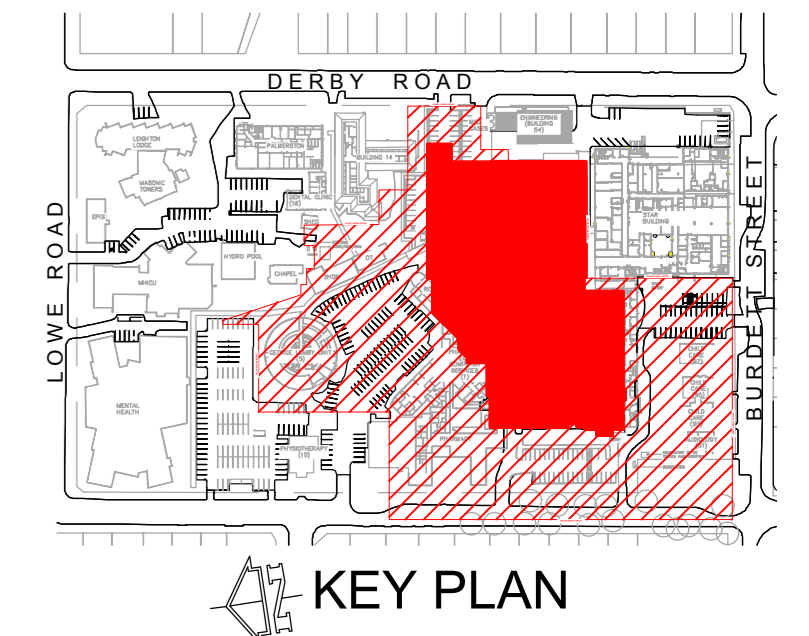

Rev	Description	Eng	Draw	Date
1	ISSUE FOR CONSTRUCTION	SH	JH	28.06.18

WATPAC Level 10, 155 Clarence Street Sydney NSW 2000

STH SILVER THOMAS HANLEY 3 Glenfern Road Glen Iris Victoria 3146

Mechanical & Electrical: NSW, VIC, QLD, WA, SA, NT, ACT, TAS, NSW

Hydraulic & Fire: NSW, VIC, QLD, WA, SA, NT, ACT, TAS, NSW

Client: **NSW Health Infrastructure** Level 8, 77 Pacific Highway, North Sydney NSW 2060

Project: **HORNSBY KU-RING-GAI HOSPITAL - STAGE 2** Palmerston Road, Hornsby NSW 2077

Sheet Subject: **DETAILS SHEET 1**

Civil Engineer: **TTW Taylor Thomson Whitting** 612 9439 7288 | 48 Chandos Street St Leonards NSW 2055

Scale: AS SHOWN Drawing No: 161607 CIV-DNG-30-901

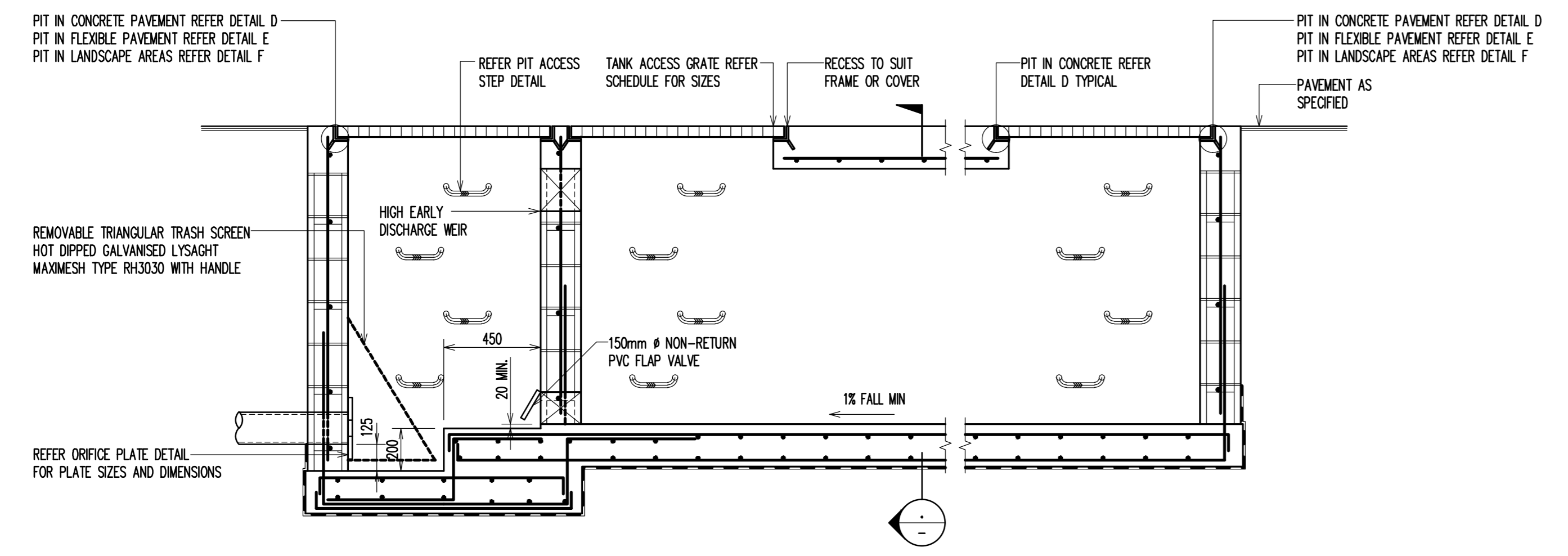
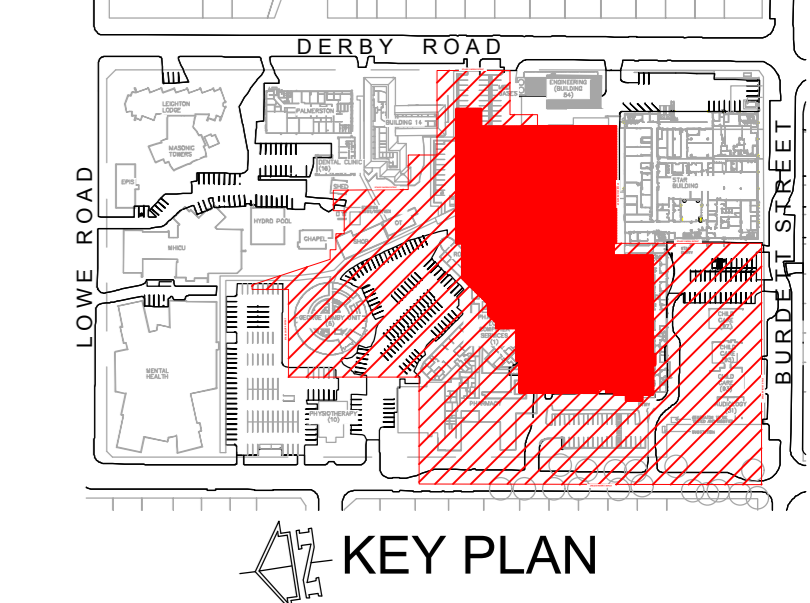

SECTION THROUGH DETENTION TANK
SCALE 1:20

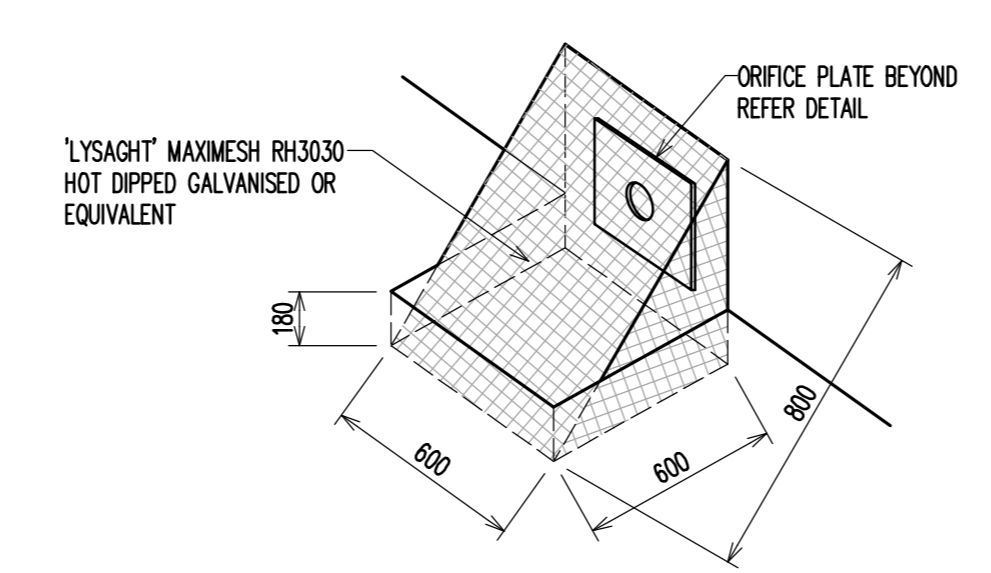

TRASH SCREEN DETAIL
N/S

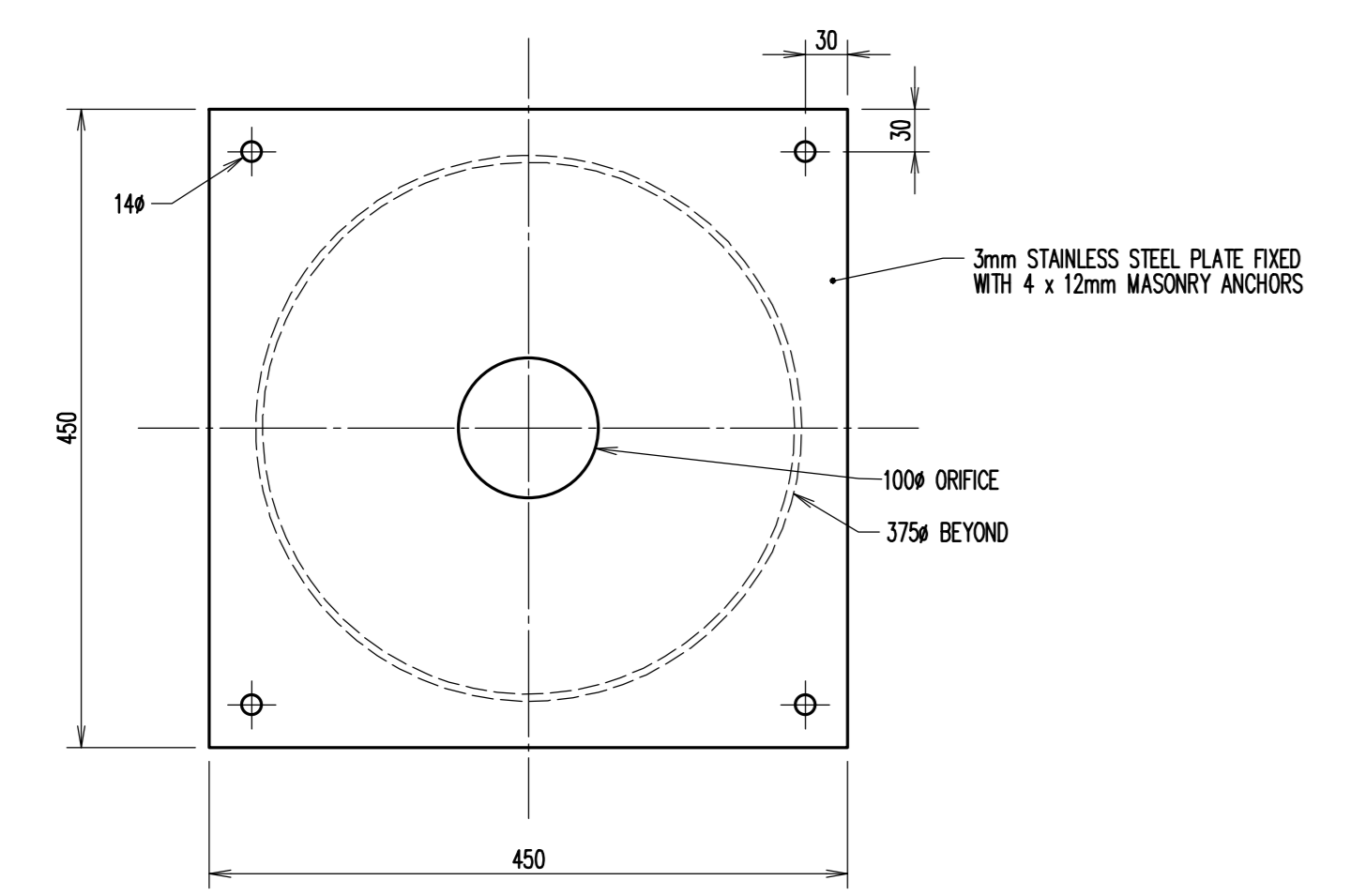

ORIFICE PLATE DETAIL (OSD TANK 2)
SCALE 1:5

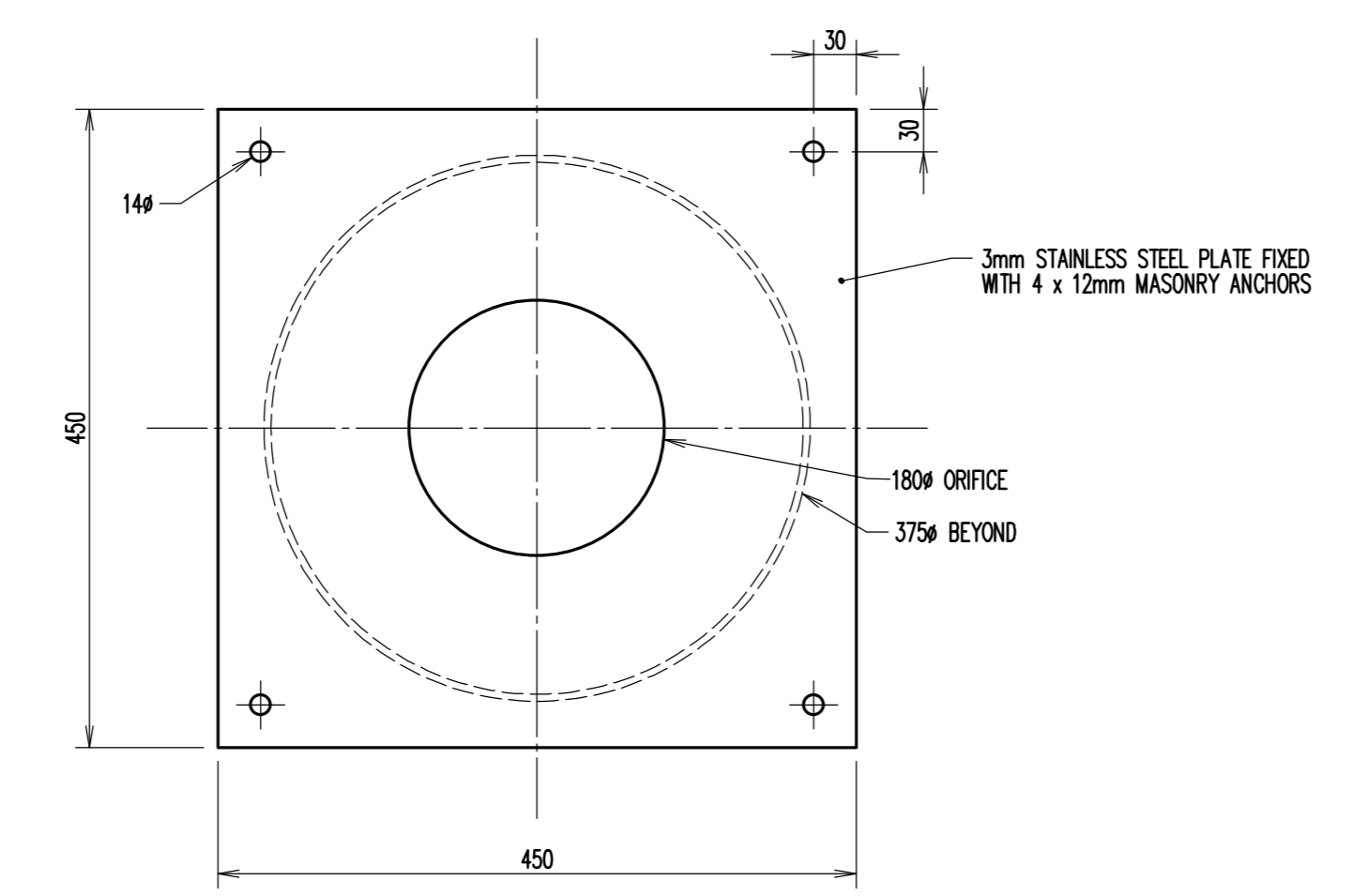

ORIFICE PLATE DETAIL (OSD TANK 1)
SCALE 1:5

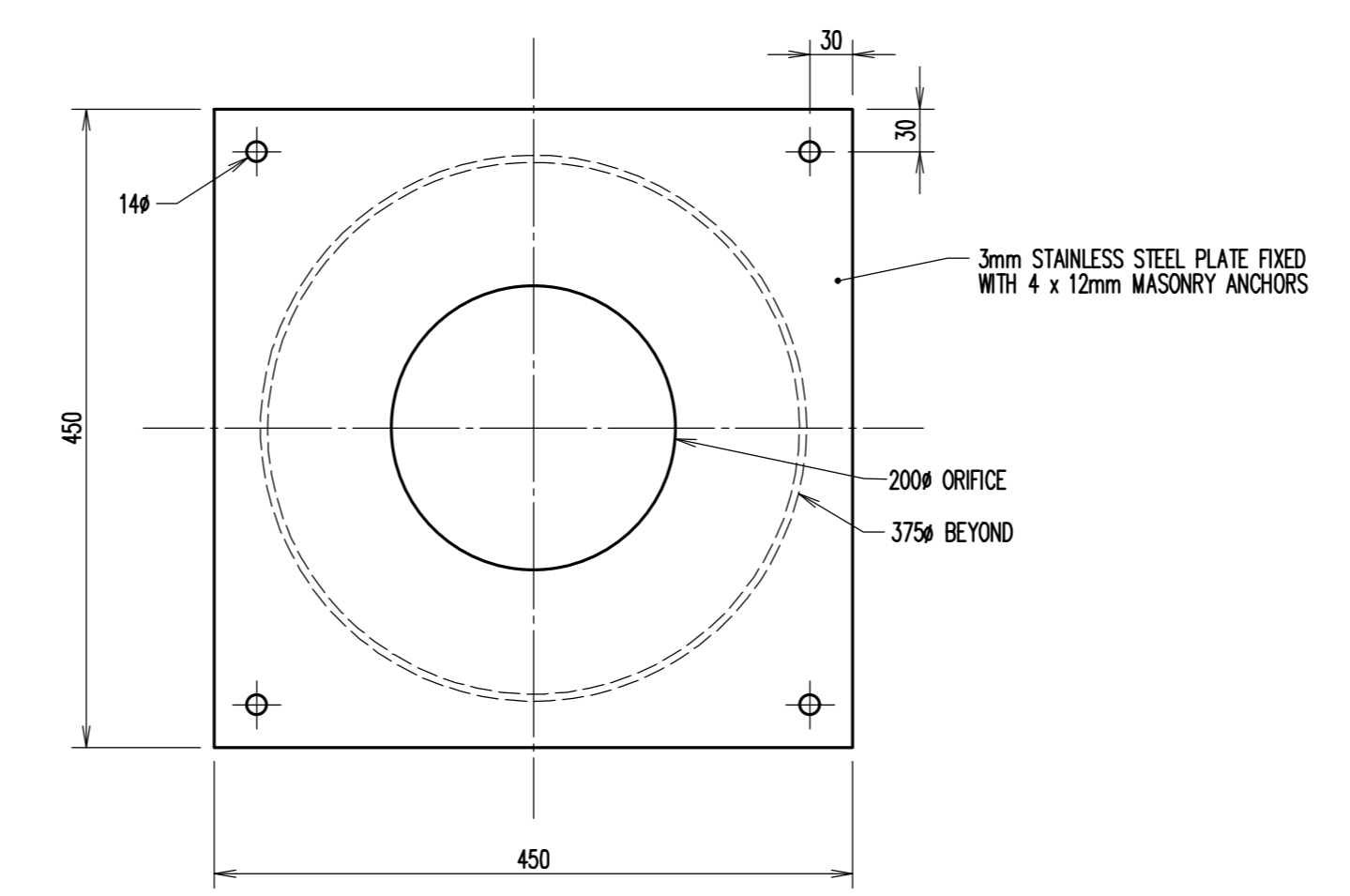

ORIFICE PLATE DETAIL (FLOW CONTROL PIT)
SCALE 1:5

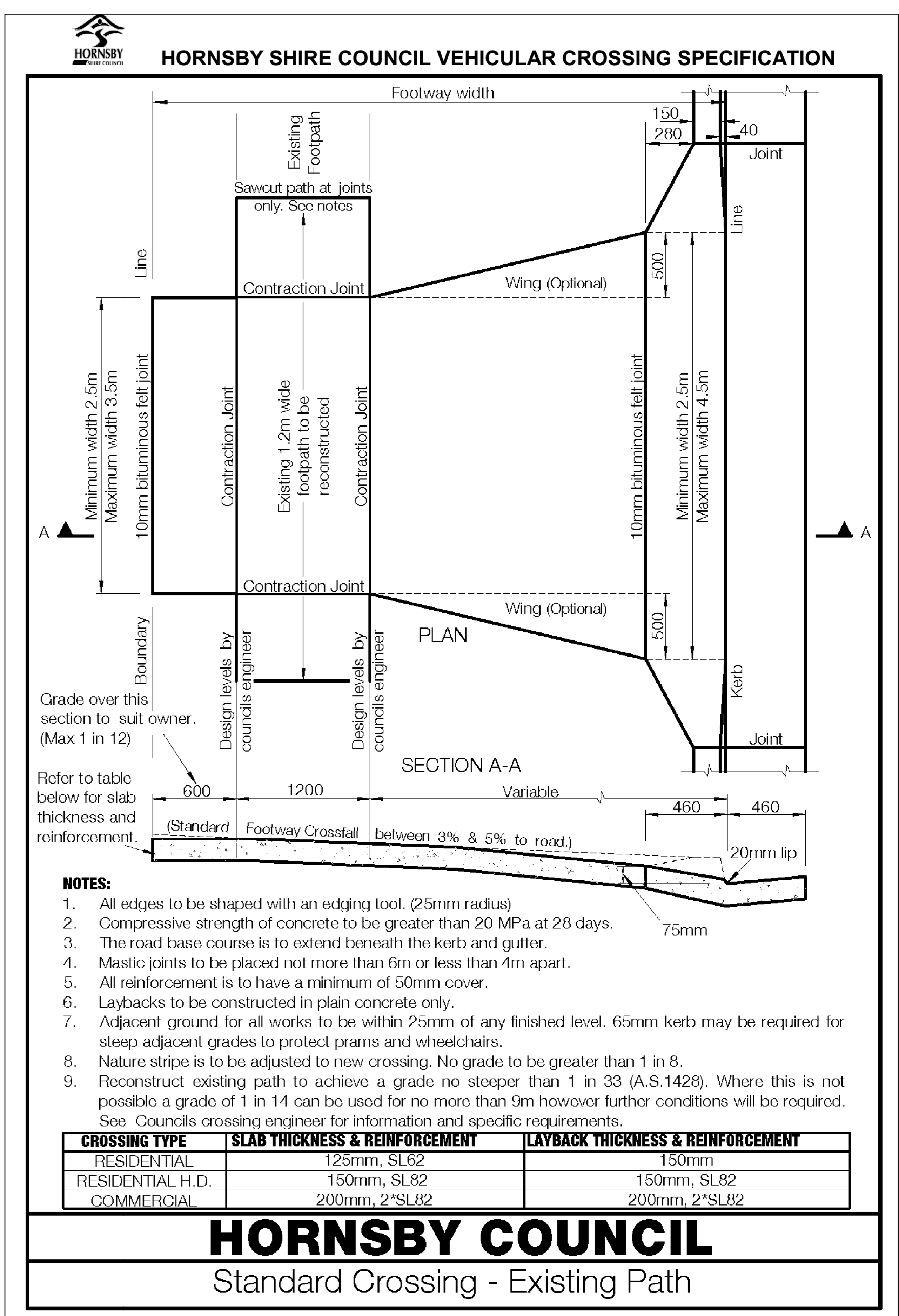

- NOTES:**
- All edges to be shaped with an edging tool. (25mm radius)
 - Compressive strength of concrete to be greater than 20 MPa at 28 days.
 - The road base course is to extend beneath the kerb and gutter.
 - Mastic joints to be placed not more than 6m or less than 4m apart.
 - All reinforcement is to have a minimum of 50mm cover.
 - Laybacks to be constructed in plain concrete only.
 - Adjacent ground for all works to be within 25mm of any finished level. 65mm kerb may be required for steep adjacent grades to protect prams and wheelchairs.
 - Nature stripe is to be adjusted to new crossing. No grade to be greater than 1 in 8.
 - Reconstruct existing path to achieve a grade no steeper than 1 in 33 (A.S.1429). Where this is not possible a grade of 1 in 14 can be used for no more than 9m however further conditions will be required. See Councils crossing engineer for information and specific requirements.

CROSSING TYPE	SLAB THICKNESS & REINFORCEMENT	LAYBACK THICKNESS & REINFORCEMENT
RESIDENTIAL	125mm, SL62	150mm
RESIDENTIAL H.D.	150mm, SL82	150mm, SL82
COMMERCIAL	200mm, 2*SL82	200mm, 2*SL82

HORNSBY COUNCIL
Standard Crossing - Existing Path

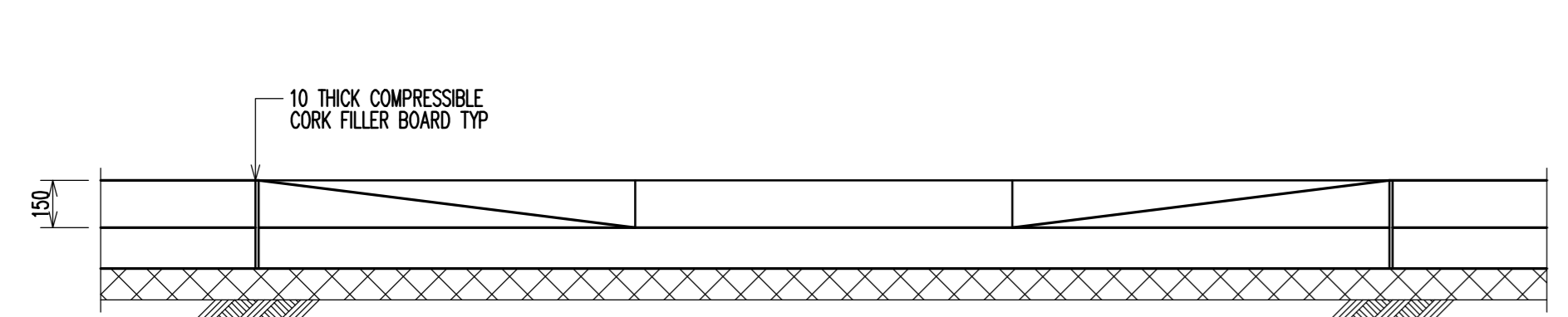

ELEVATION 8
SCALE 1:20

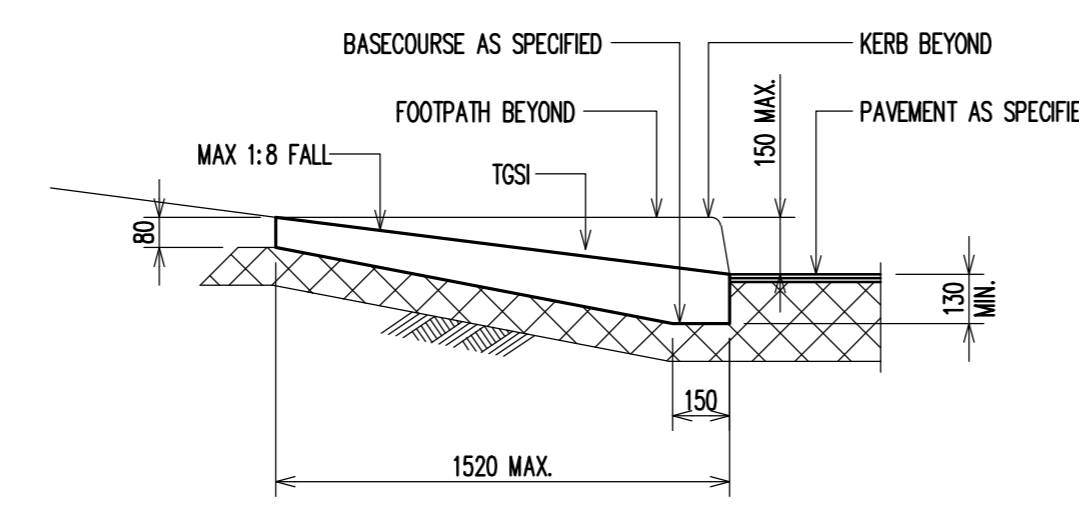

SECTION 9
SCALE 1:20

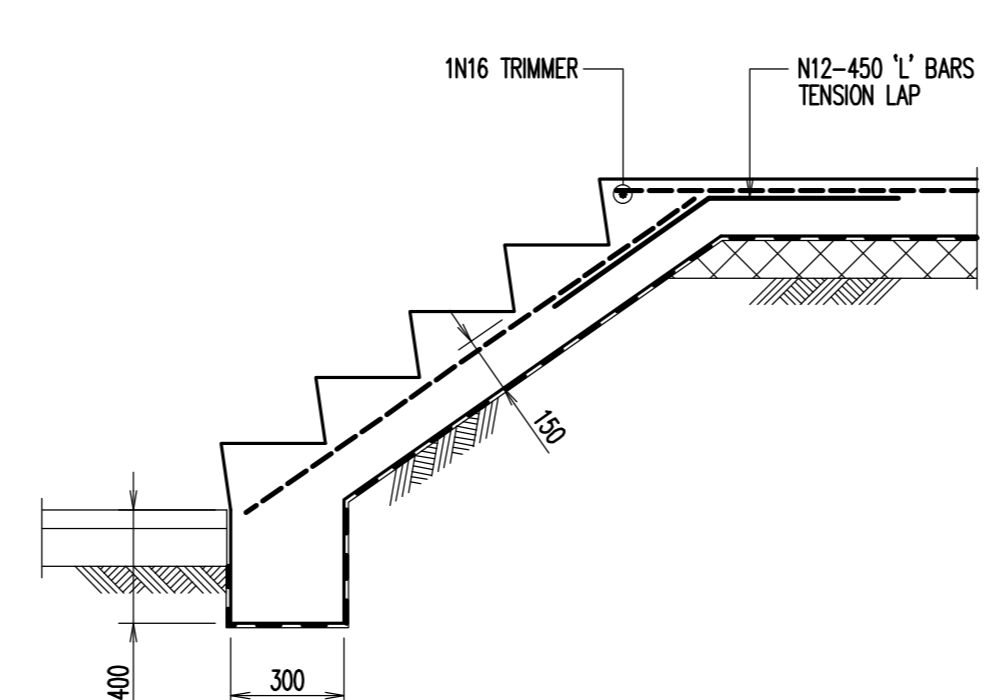

TYPICAL STAIR ON GROUND

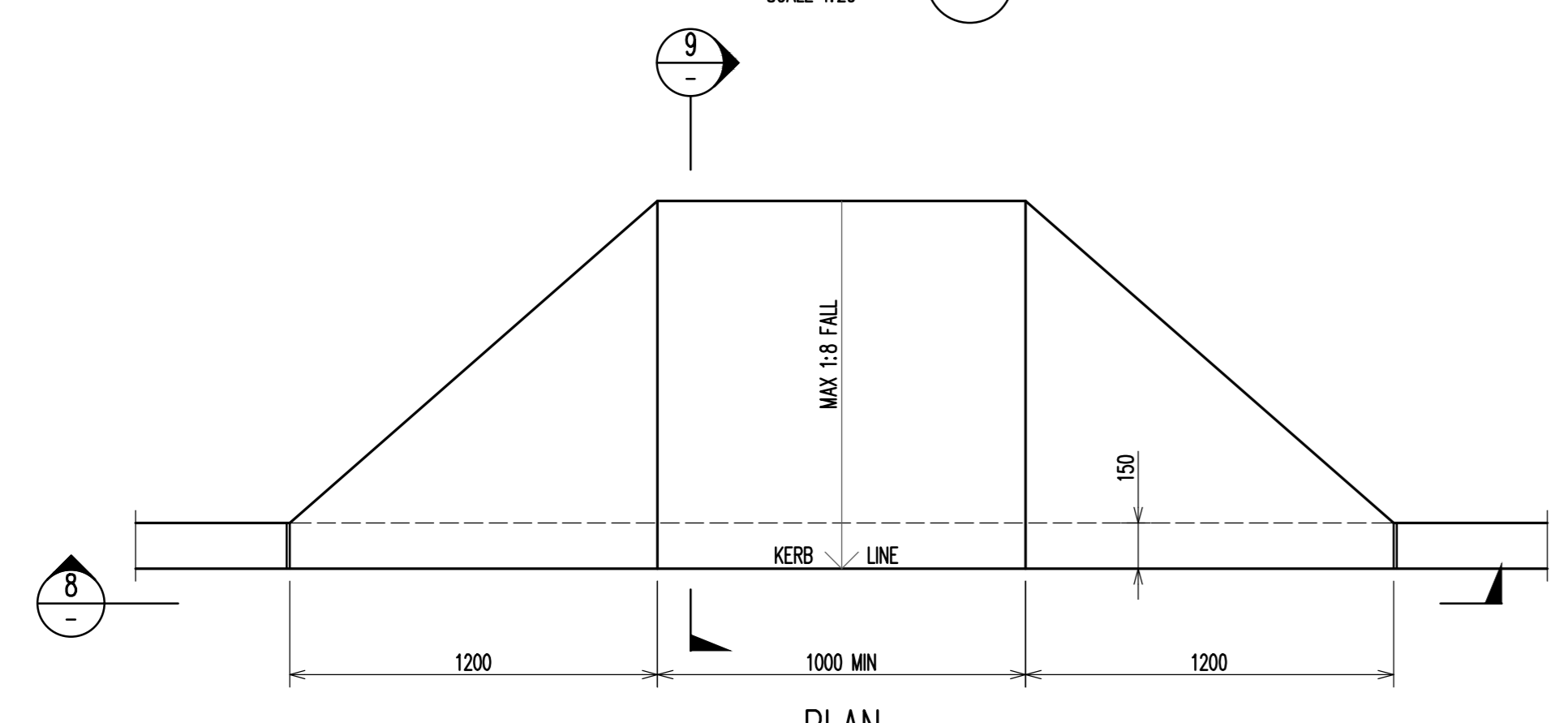

RAMPED CROSSING
SCALE 1:20

Rev	Description	Eng	Draft	Date
1	ISSUE FOR CONSTRUCTION	KH	JH	25.06.18

WATPAC Level 10, 155 Clarence Street Sydney NSW 2002
STH SILVER THOMAS HANLEY 3 Gresham Road Glen Iris Victoria 3146
 Mechanical & Electrical
 Hydraulic & Fire
 Client



Level 8, 77 Pacific Highway, North Sydney NSW 2060
 Project
HORNSBY KU-RING-GAI HOSPITAL - STAGE 2
 Palmerston Road, Hornsby NSW 2077
 Sheet Subject
DETAILS SHEET 2

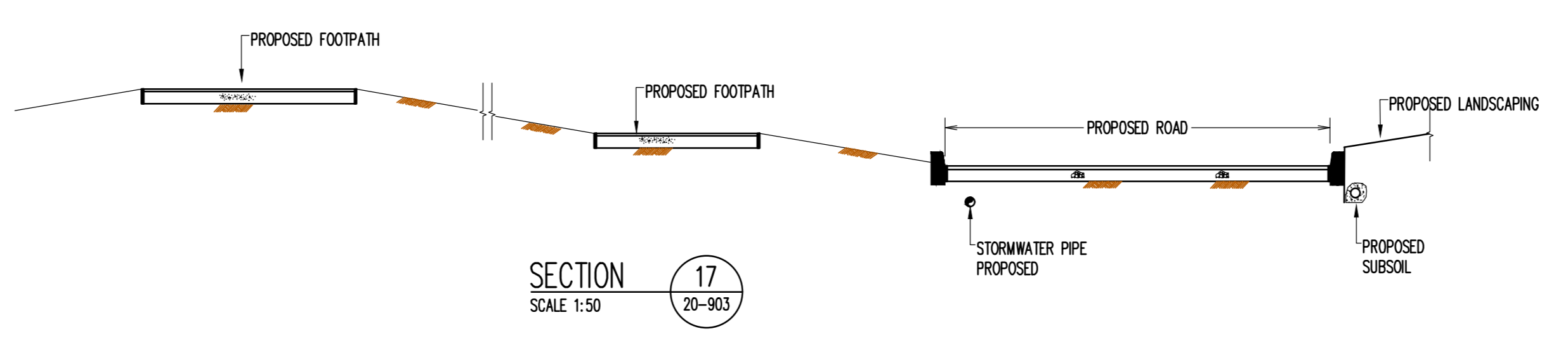
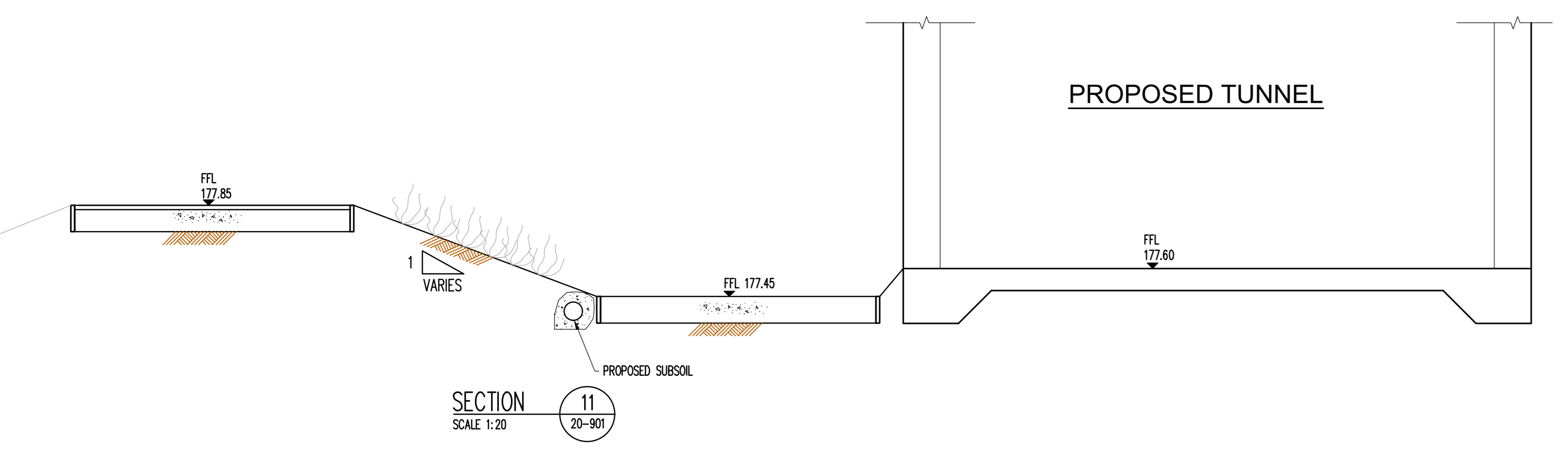
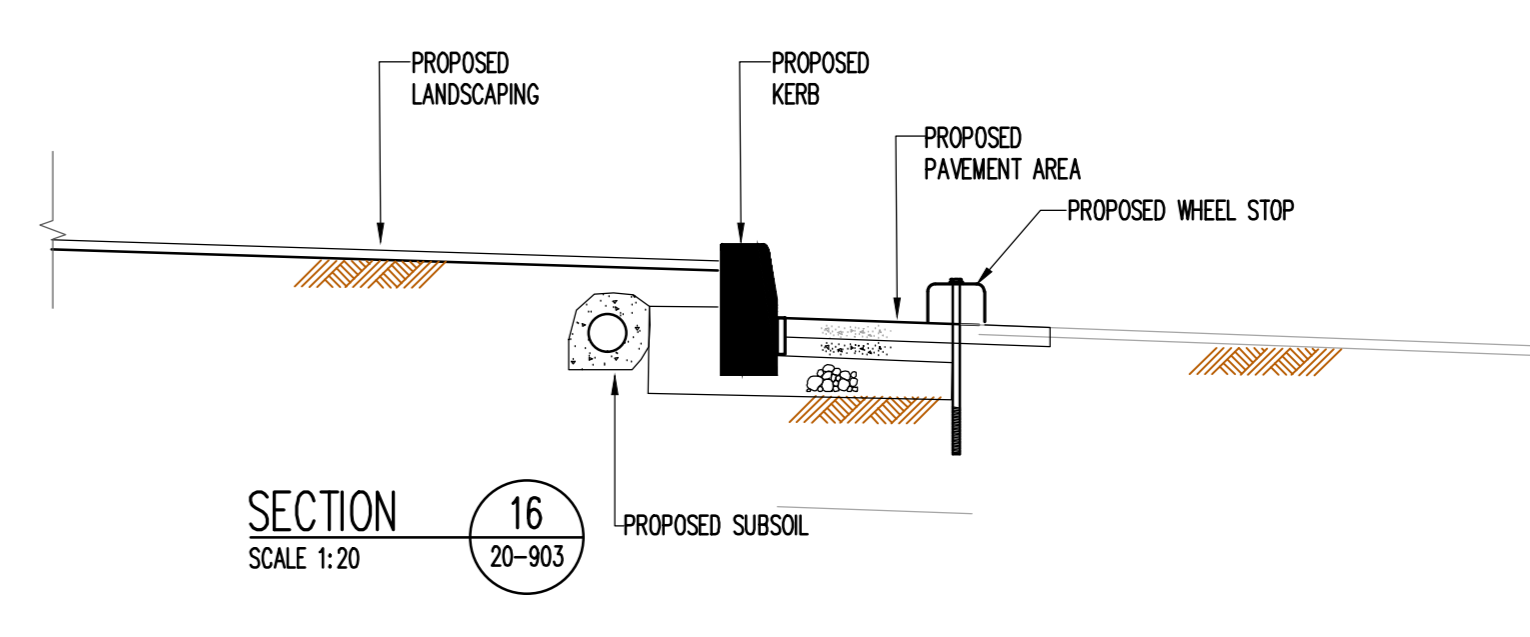
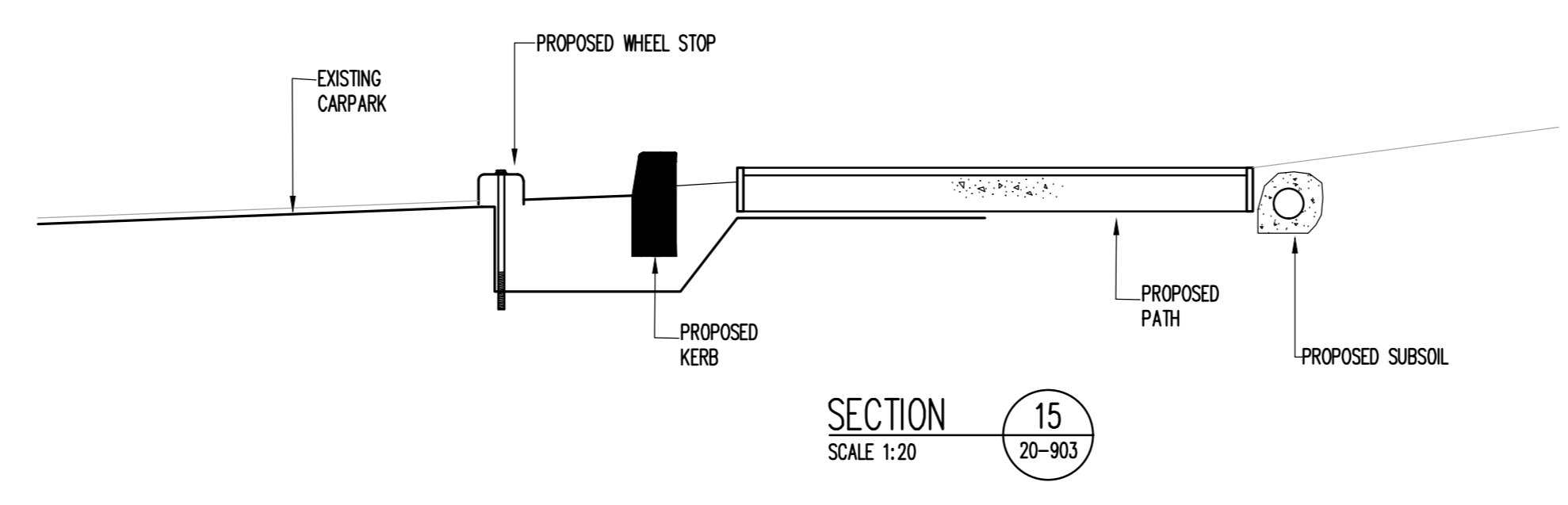
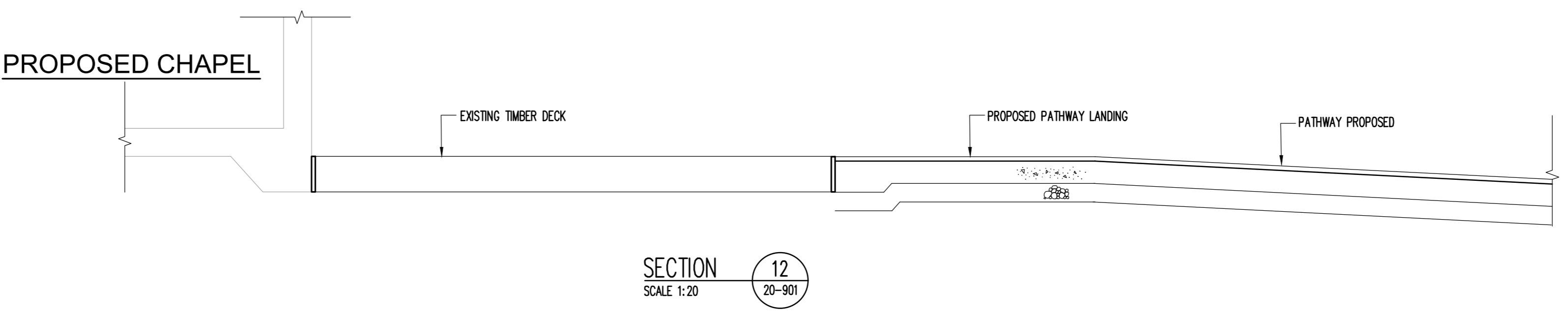
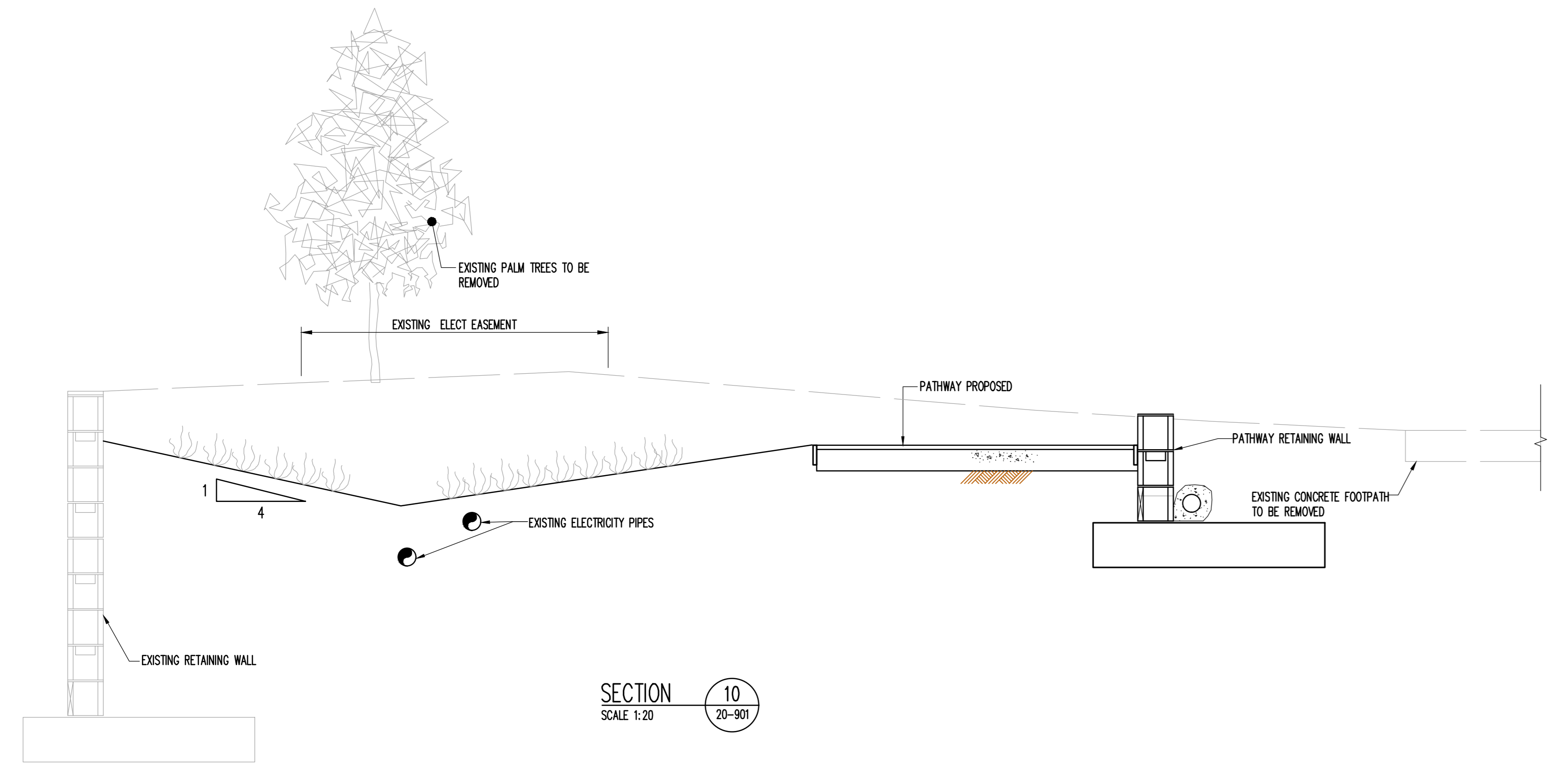
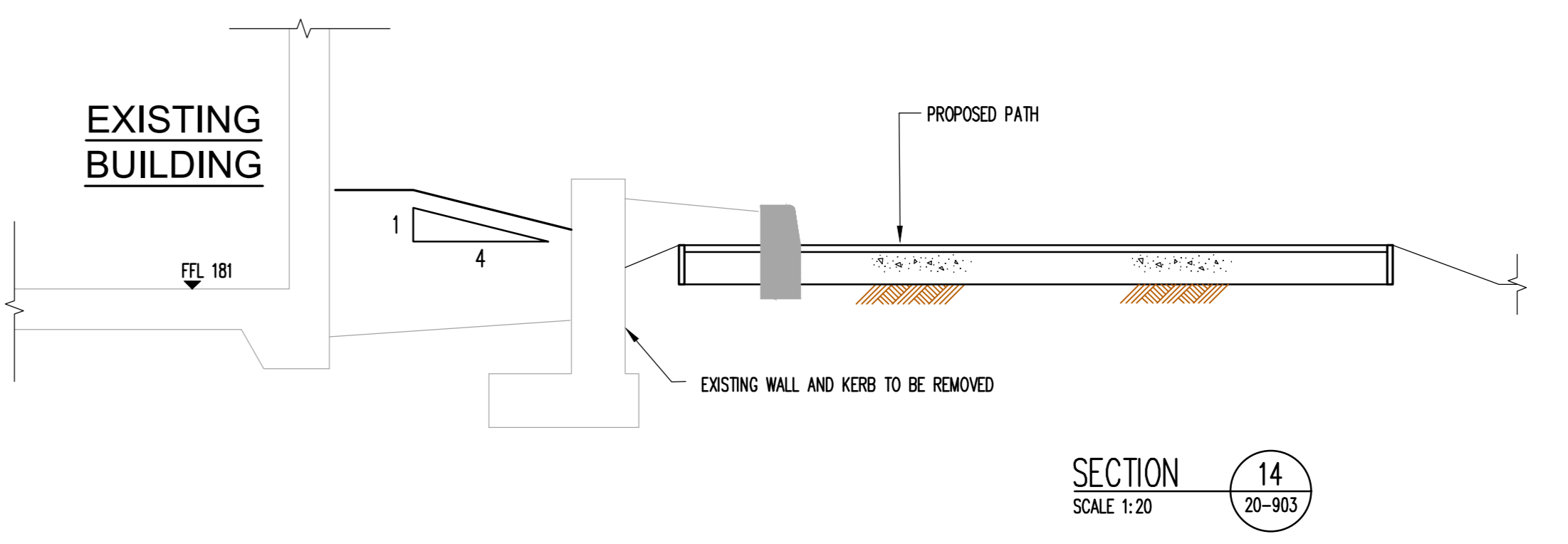
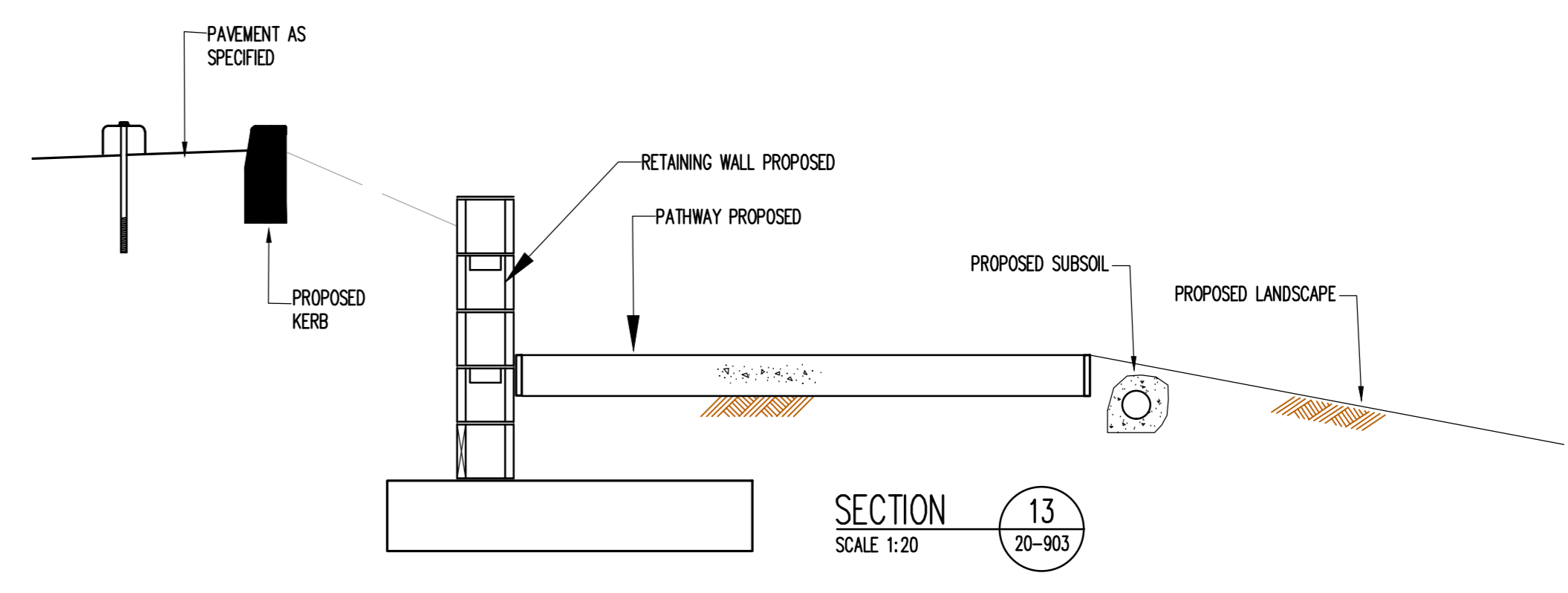
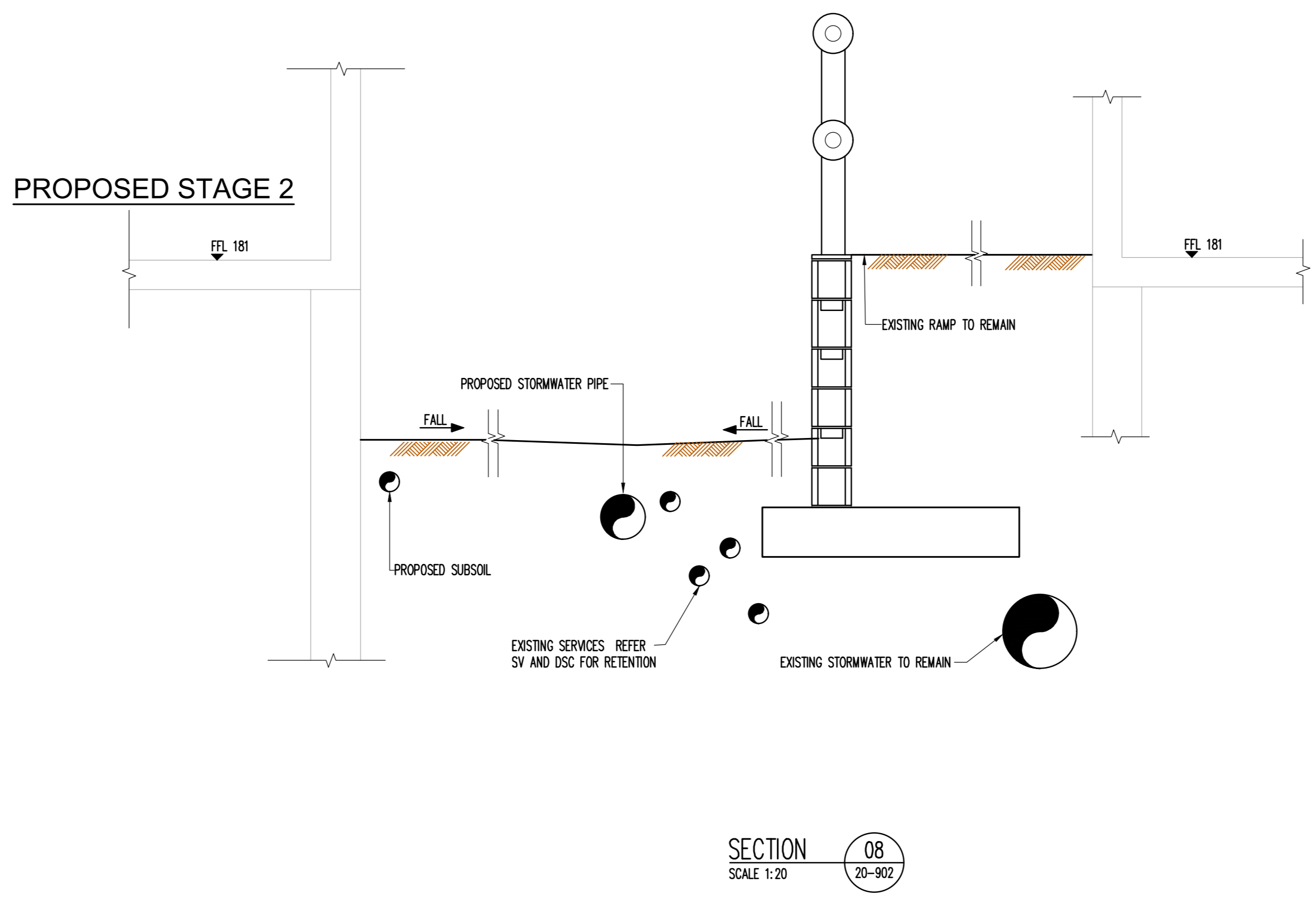
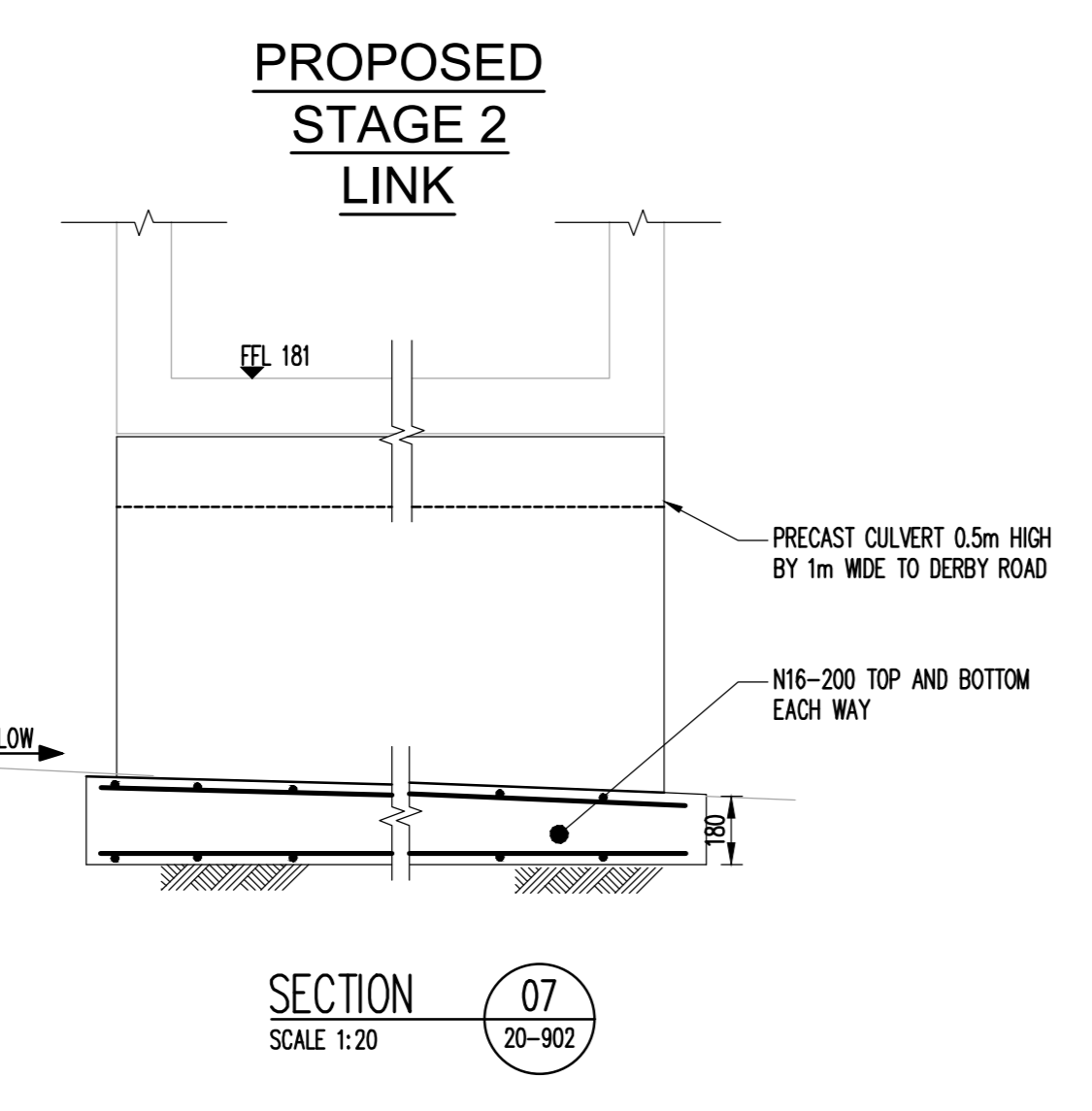
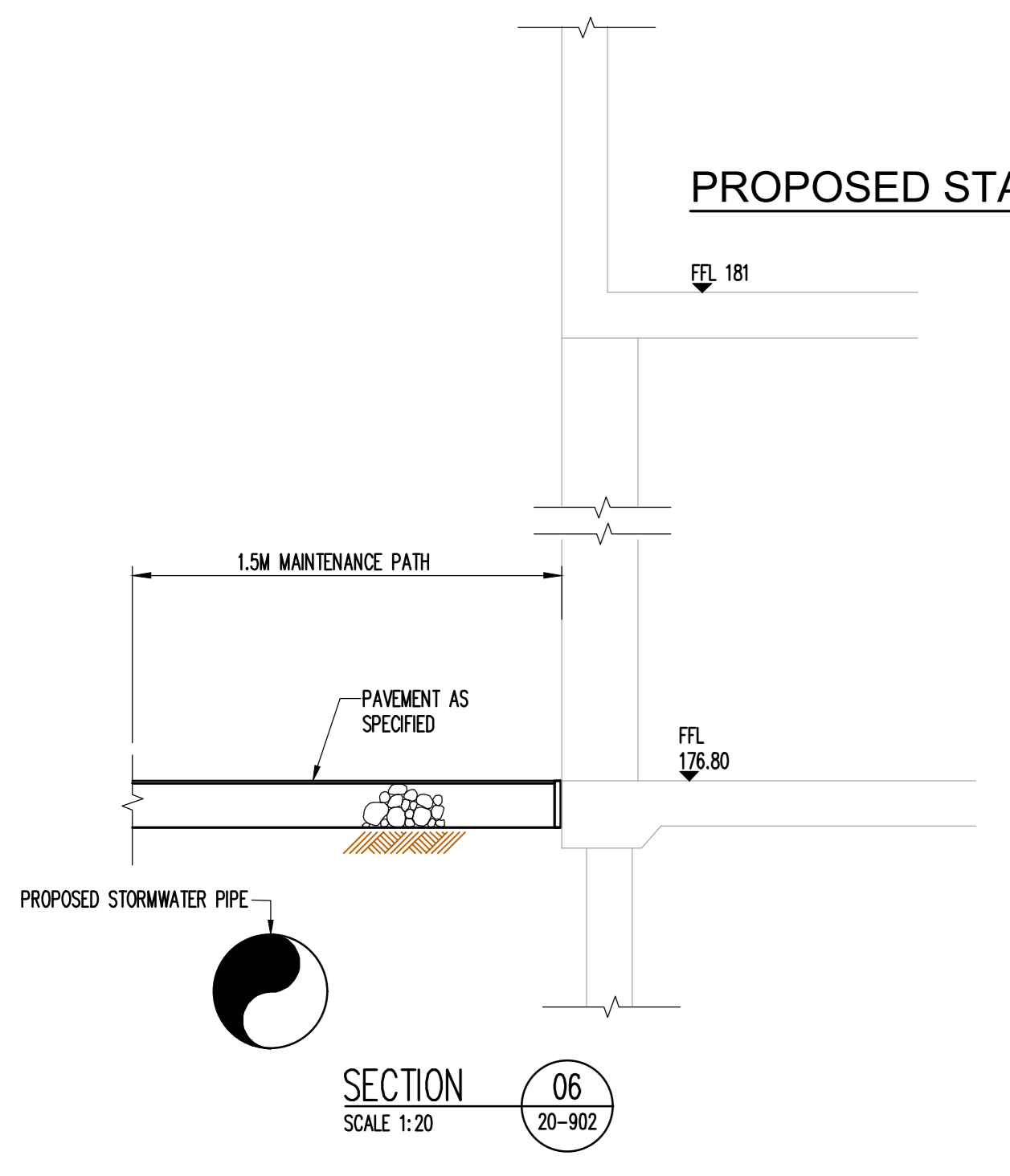
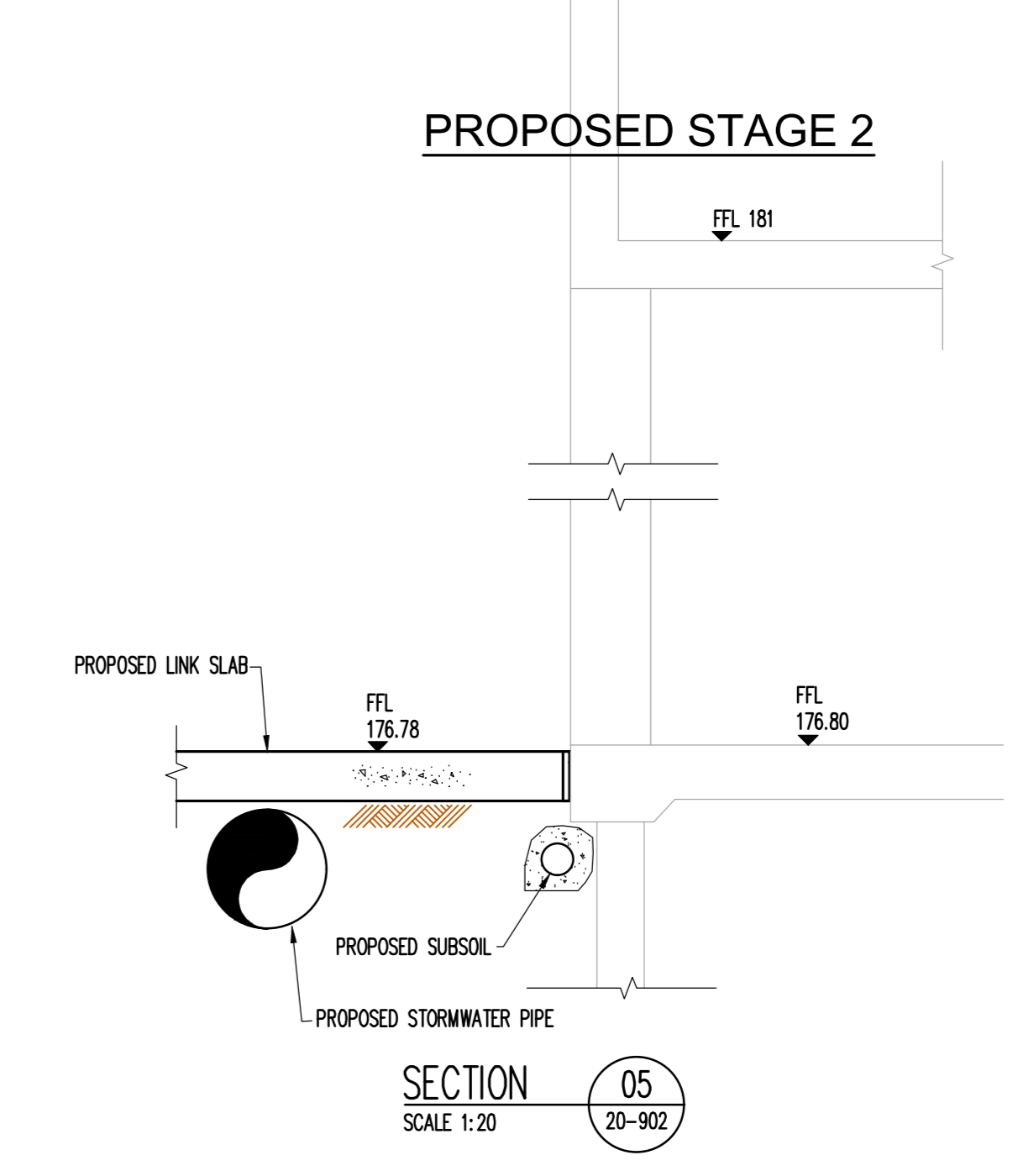
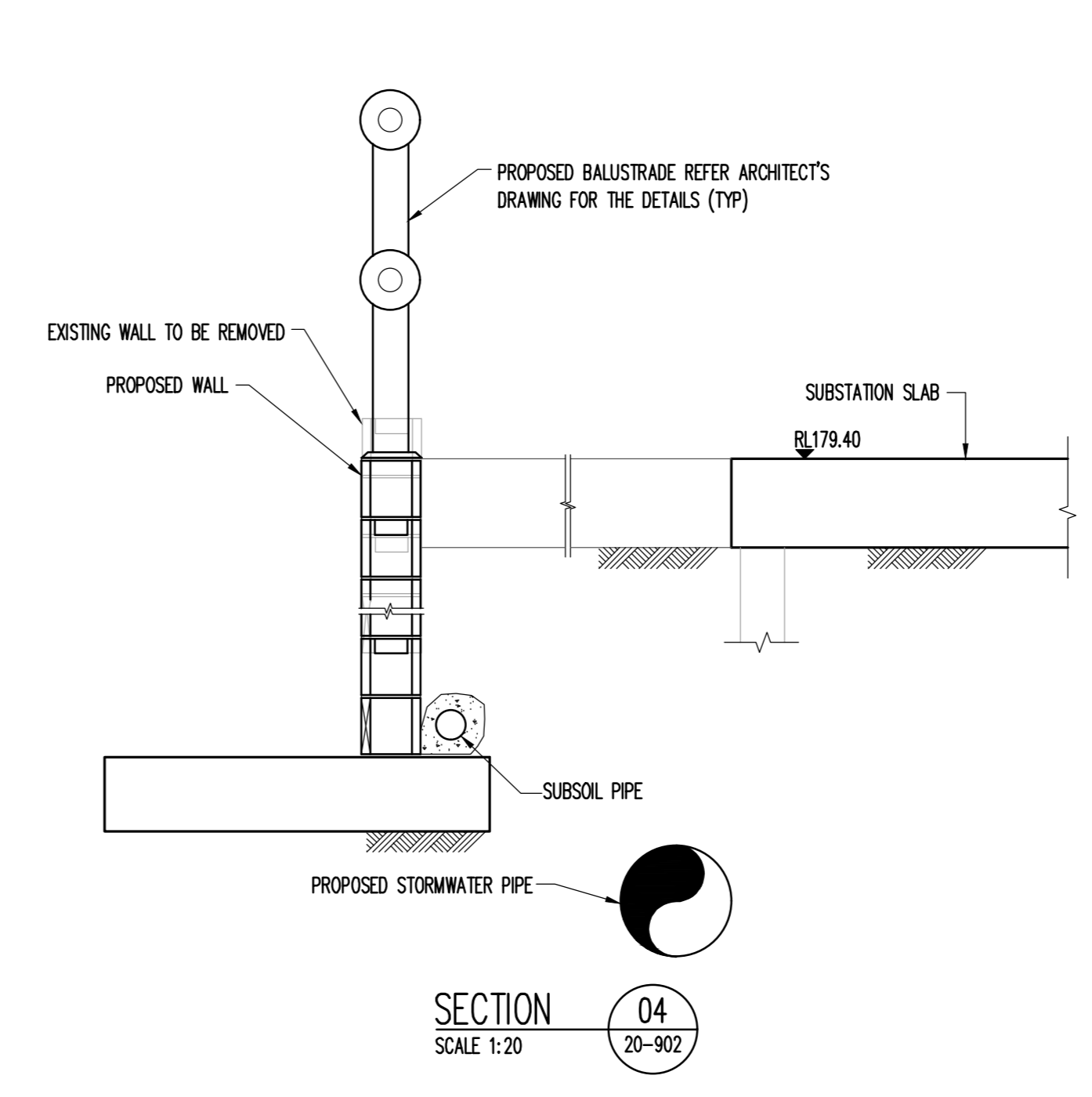
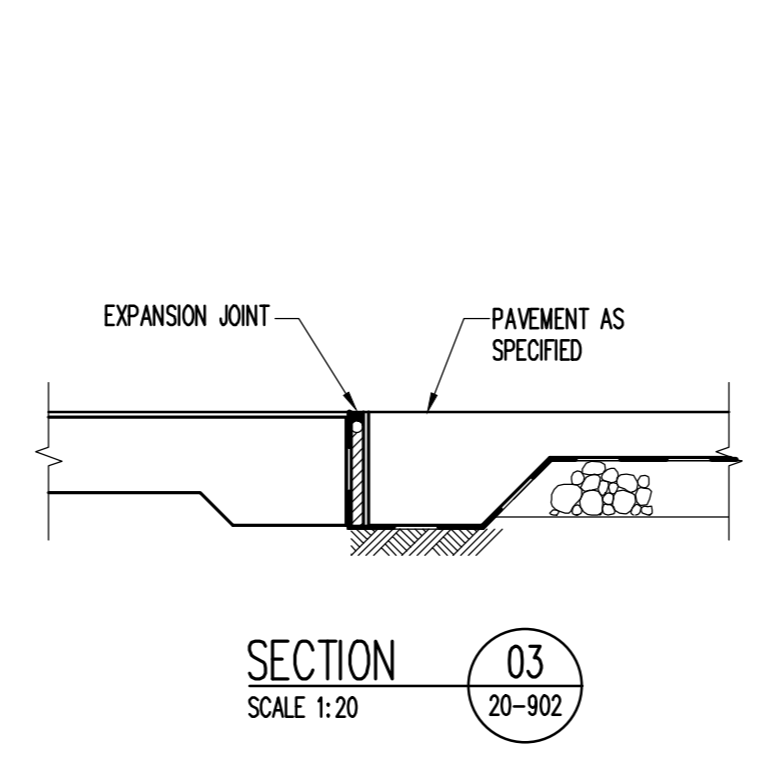
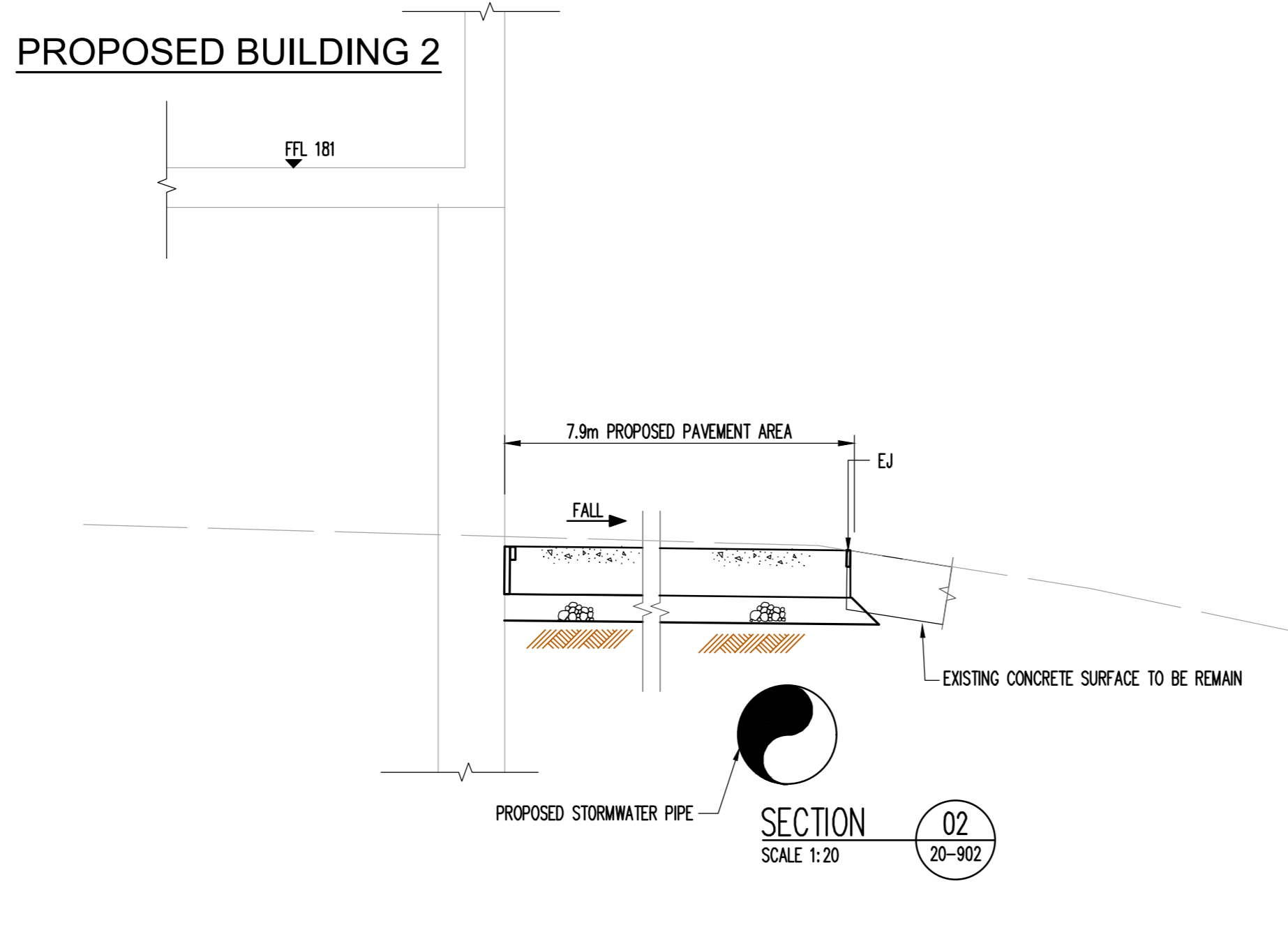
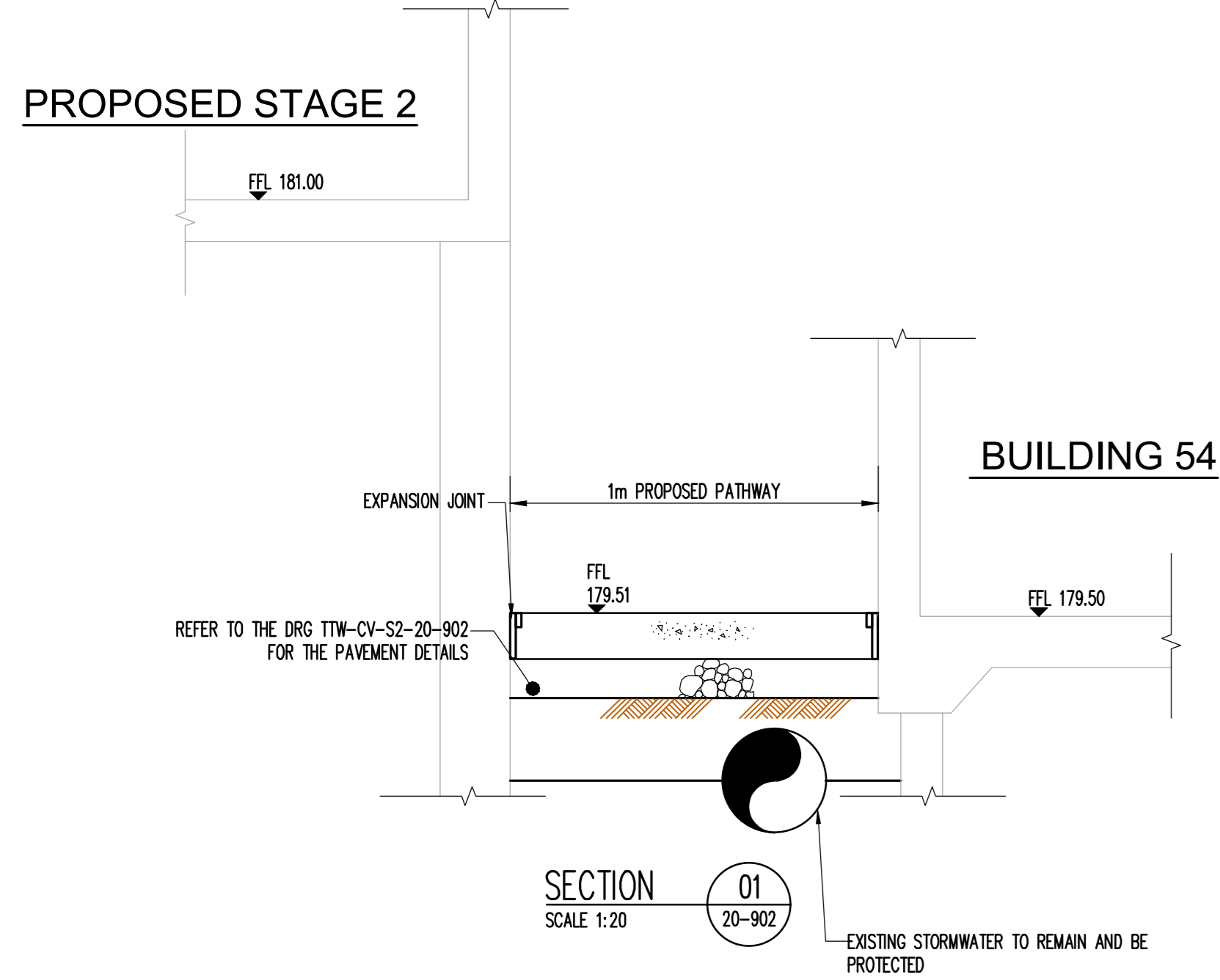
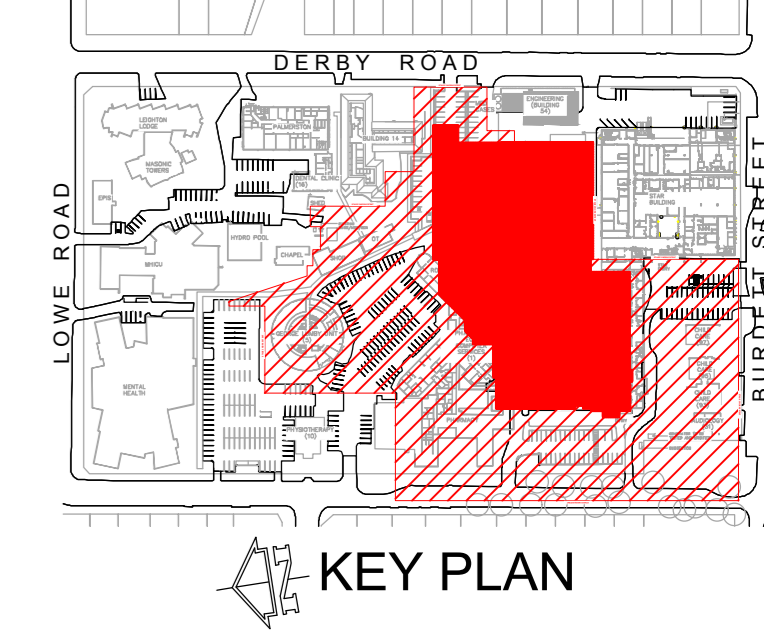

Rev	Description	Eng	Draft	Date
A	ISSUE FOR CONSTRUCTION	JH	JH	28.04.18

WATPAC	Level 10, 155 Clarence Street Sydney NSW 2000
STH	SILVER THOMAS HANLEY 3 Glenarm Road Cherrybrook NSW 2140
Mechanical & Electrical NSW
Hydraulic & Fire NSW

NSW Health Infrastructure
Level 8, 77 Pacific Highway, North Sydney NSW 2060

Project:
HORNSBY KU-RING-GAI HOSPITAL - STAGE 2
Palmerston Road, Hornsby NSW 2077

SECTIONS SHEET 1

Civil Engineer
TTW Taylor Thomson Whitting
612 9439 7288 | 48 Chandos Street St Leonards NSW 2065

Scale: A0 Drawn: JH Authorised: [Signature]
AS SHOWN JH

Job No: 161607 CIV-DNG-40-901 Drawing No: [Signature] Revision: A

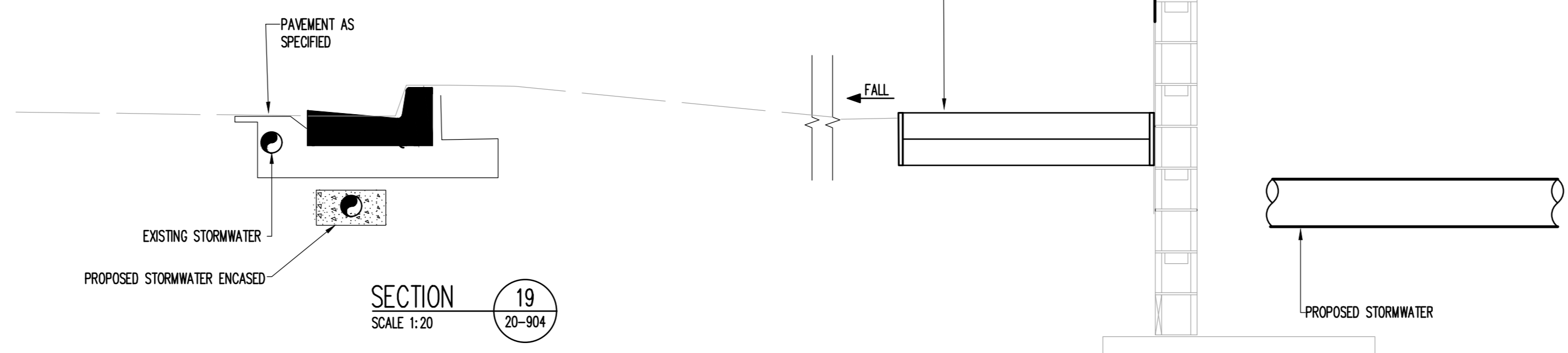
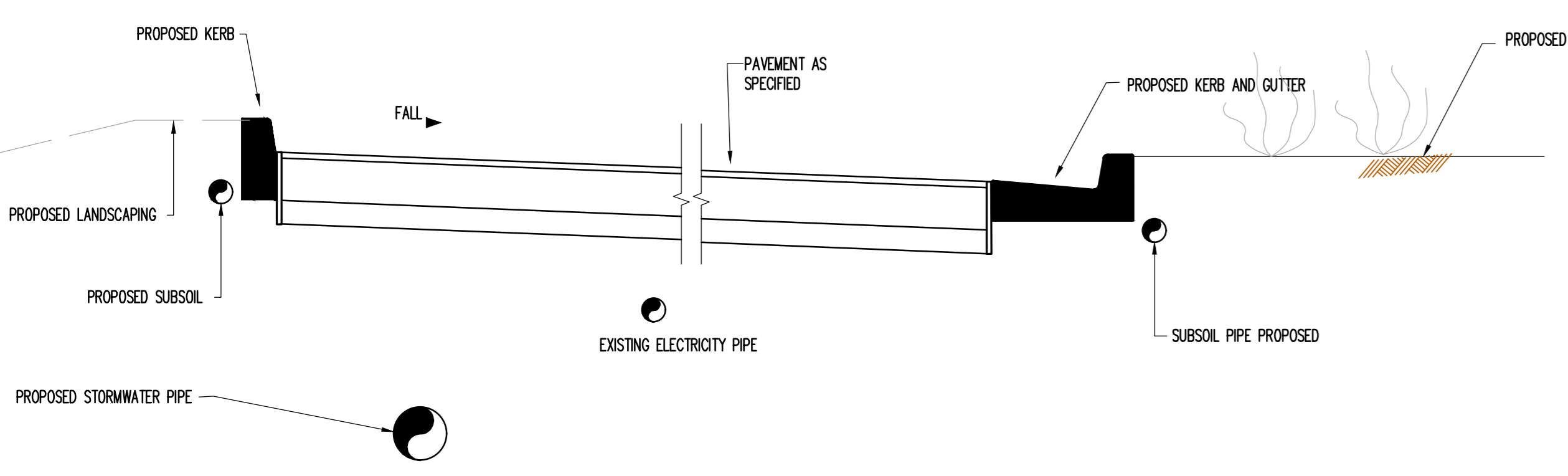
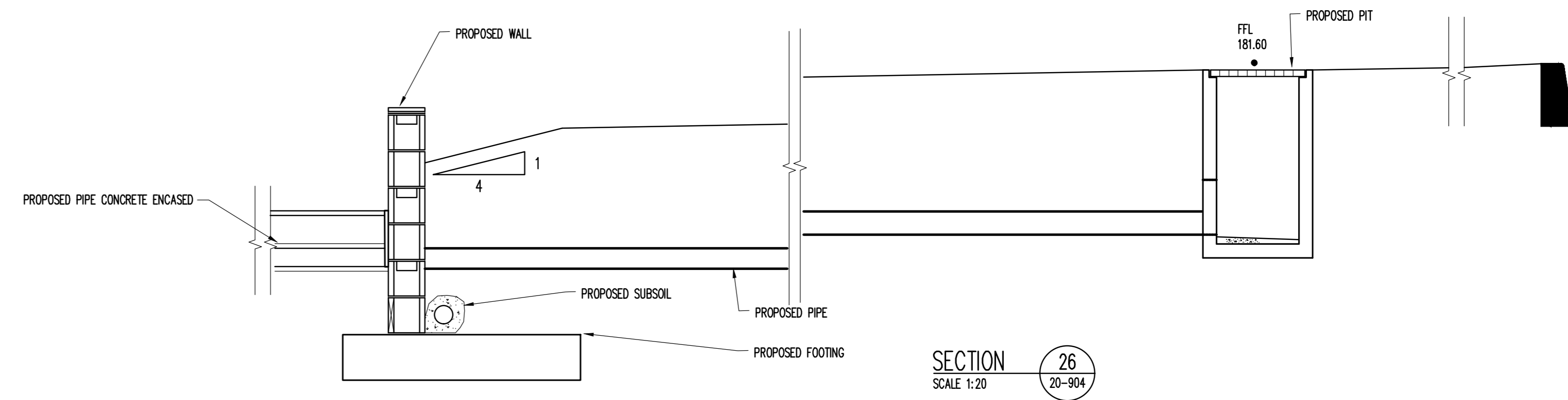
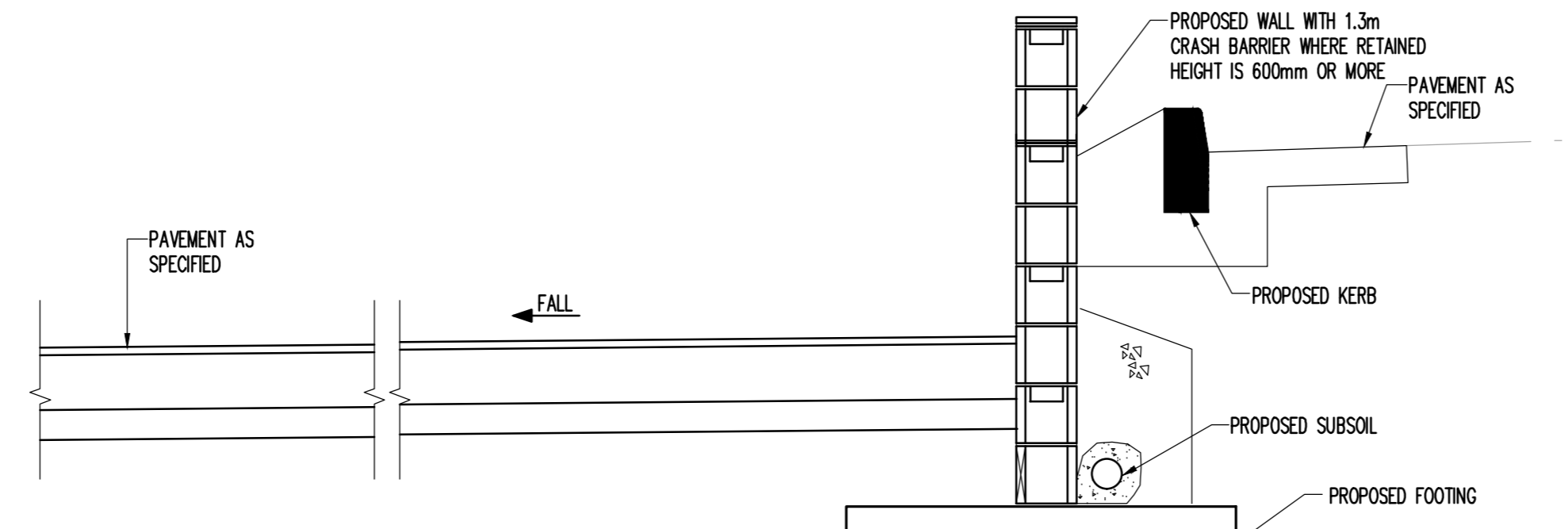
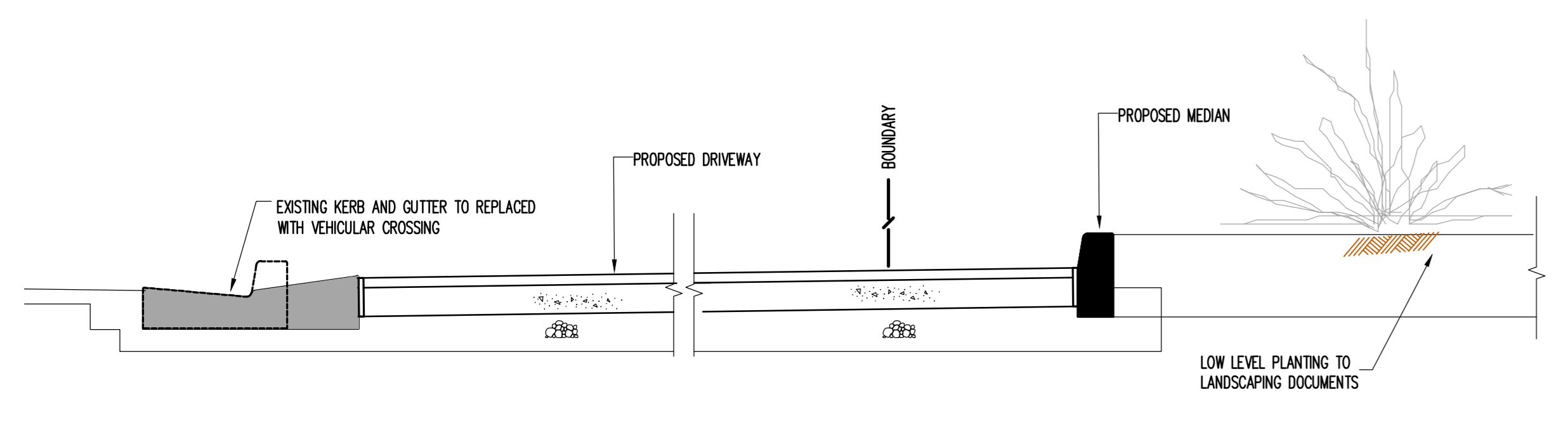
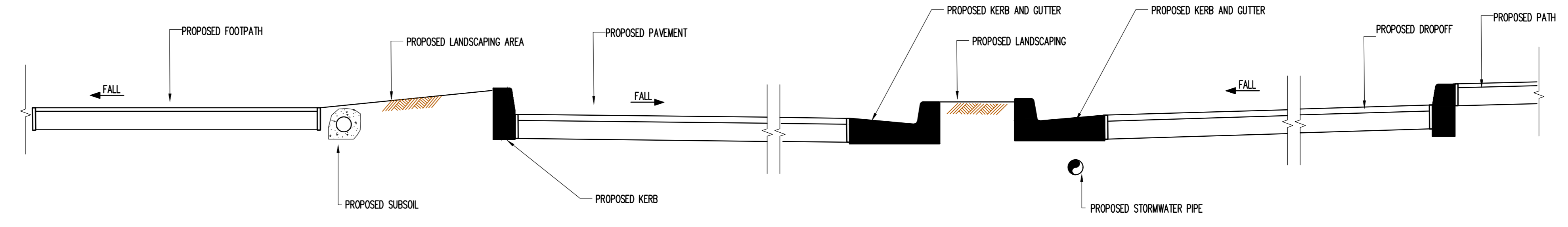
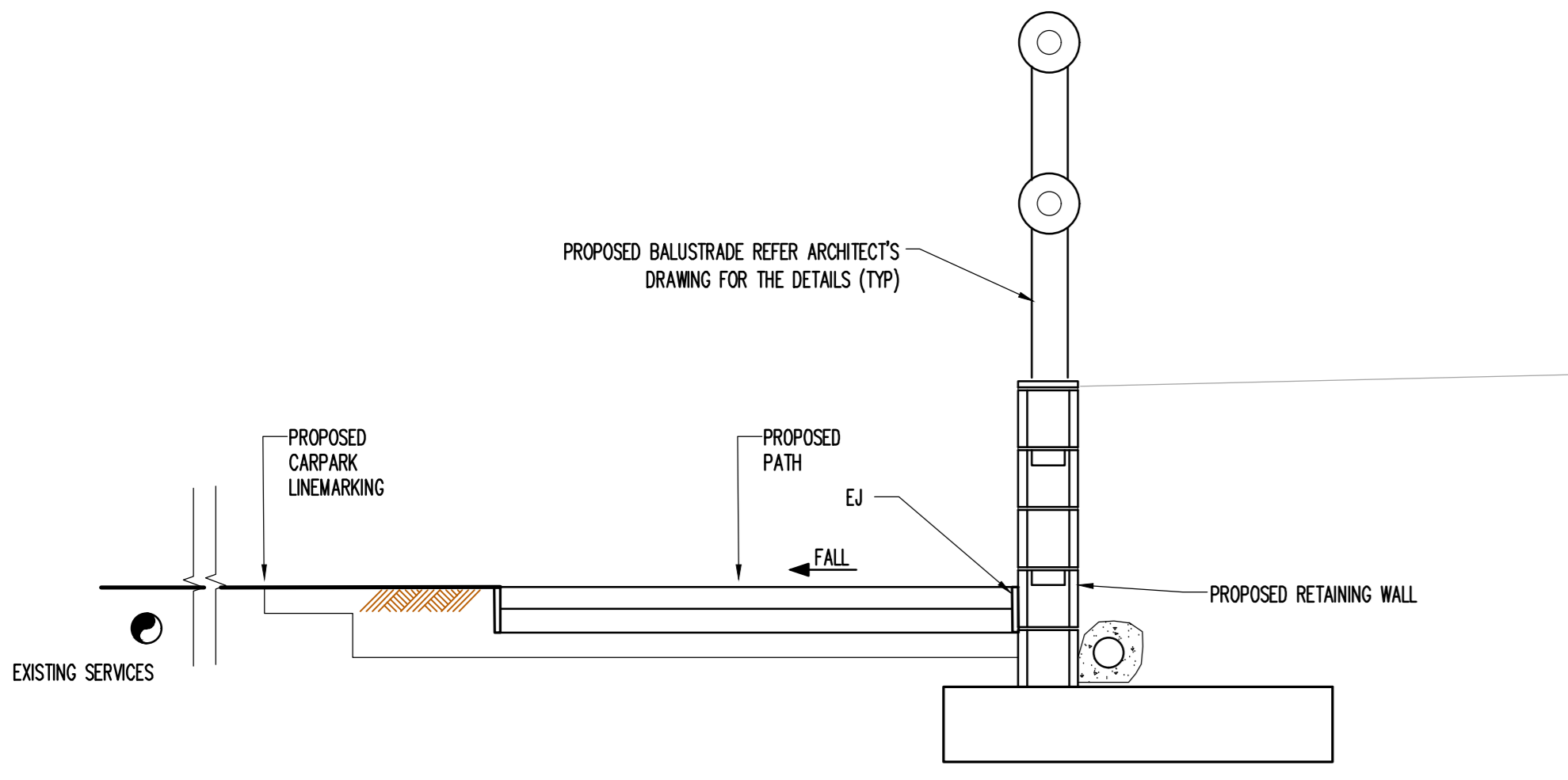
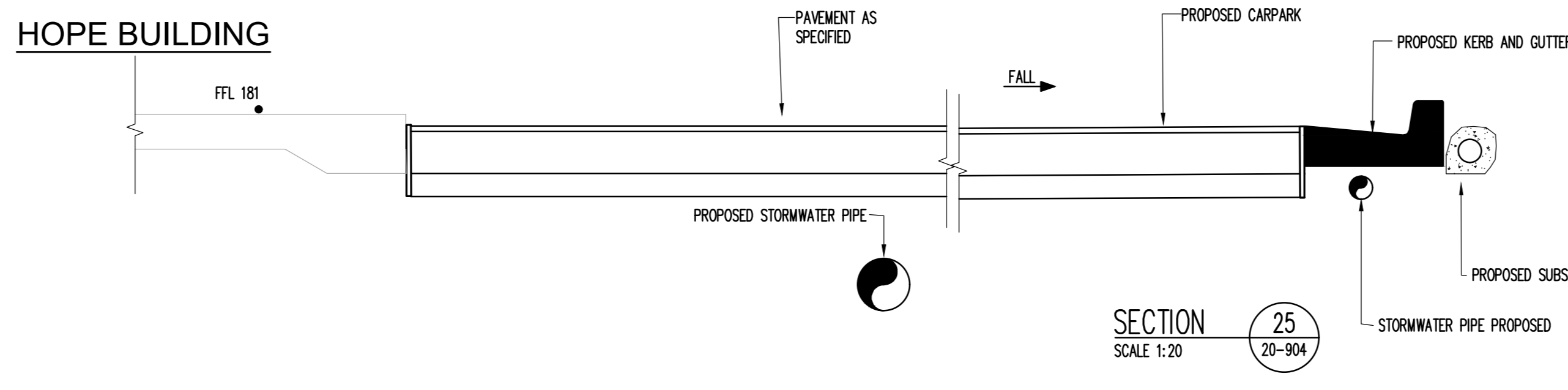
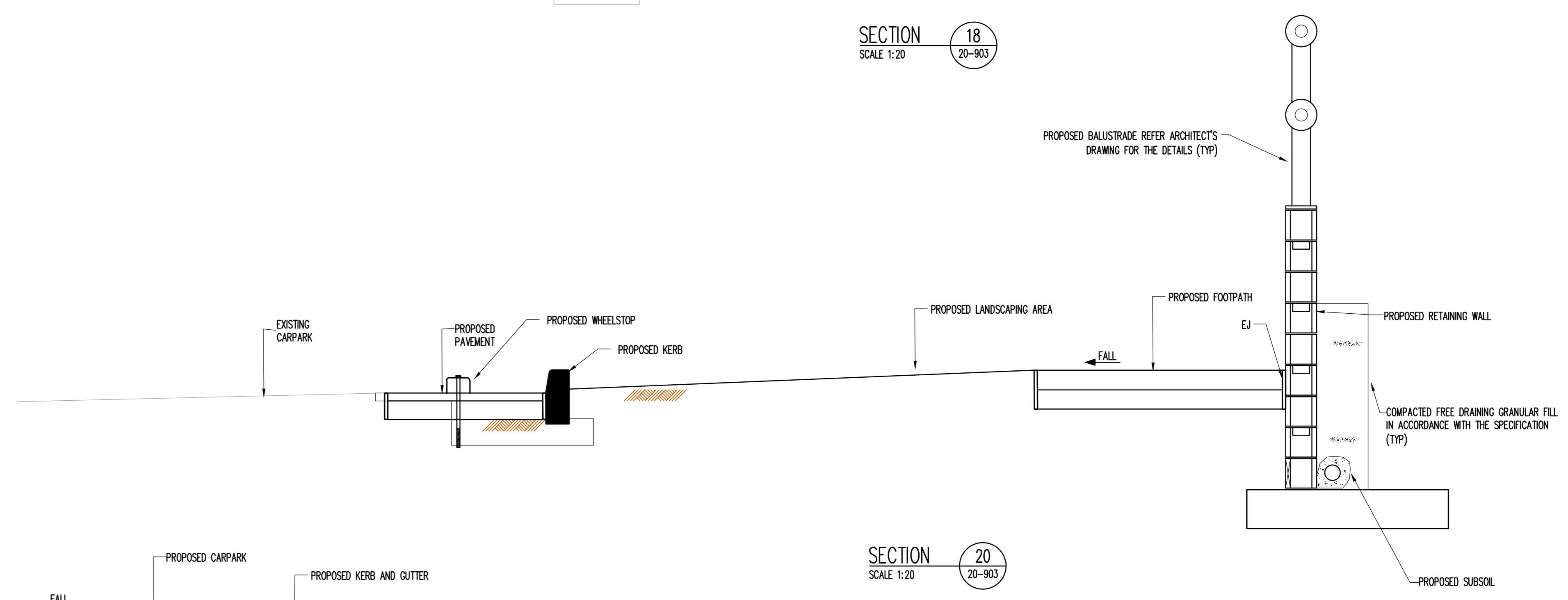
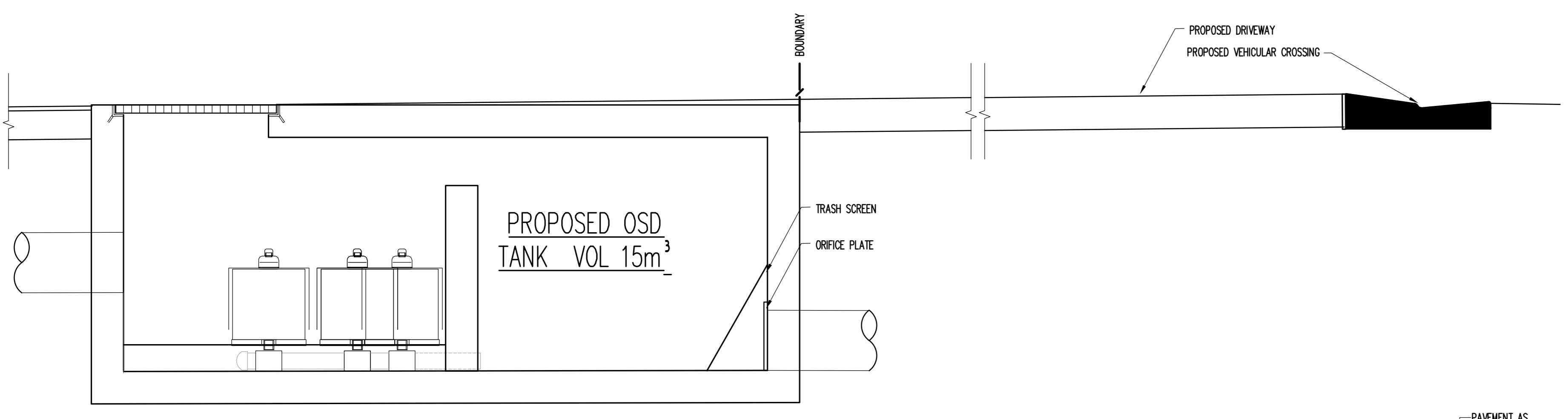
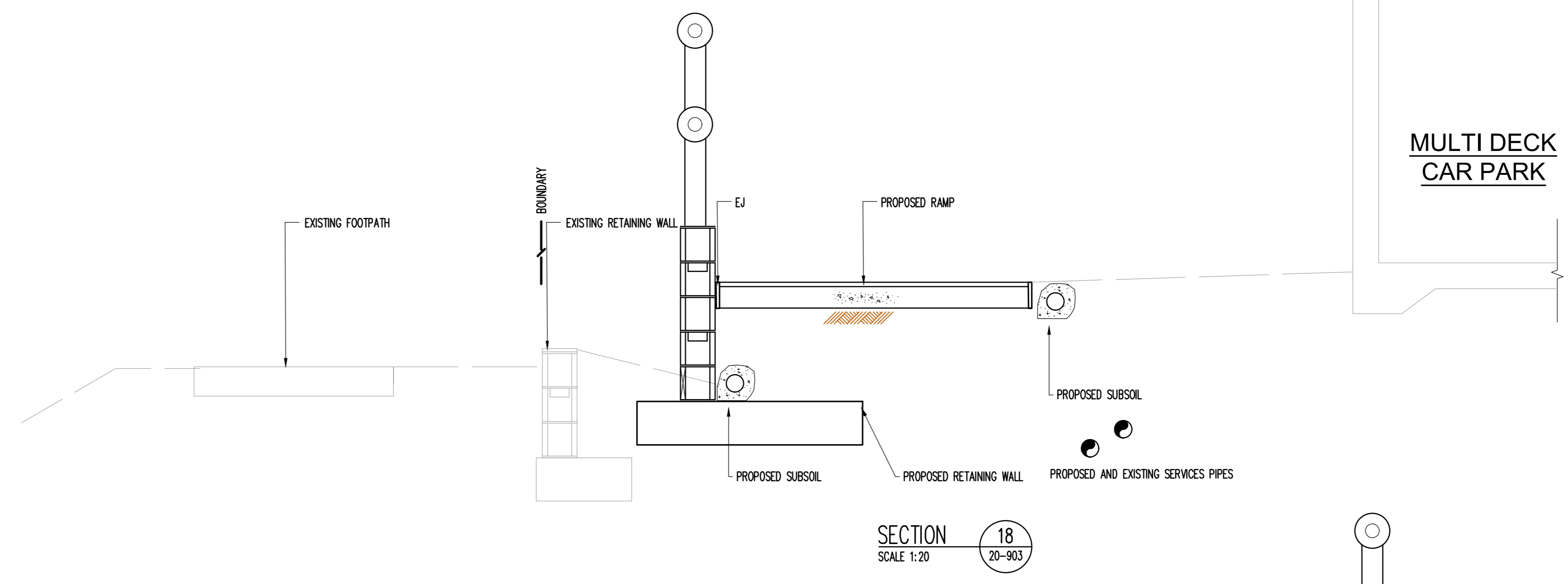
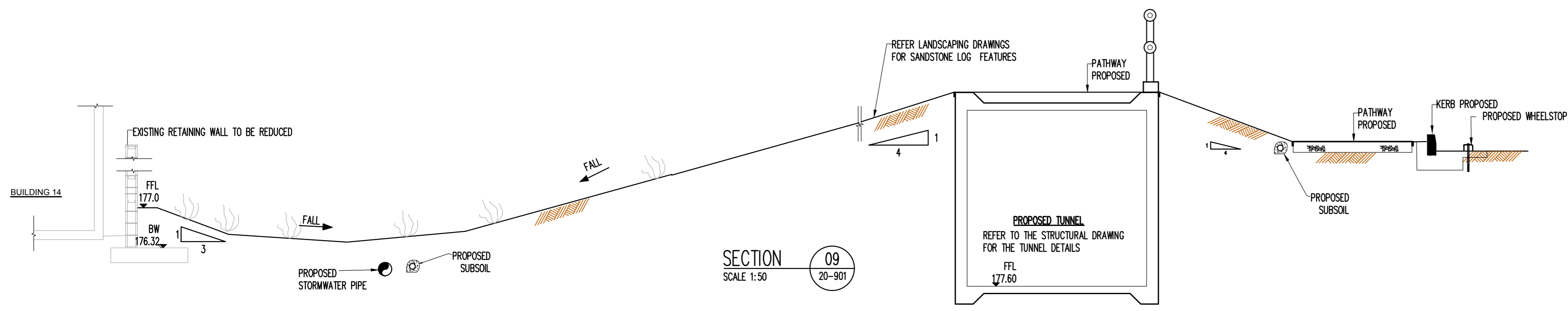
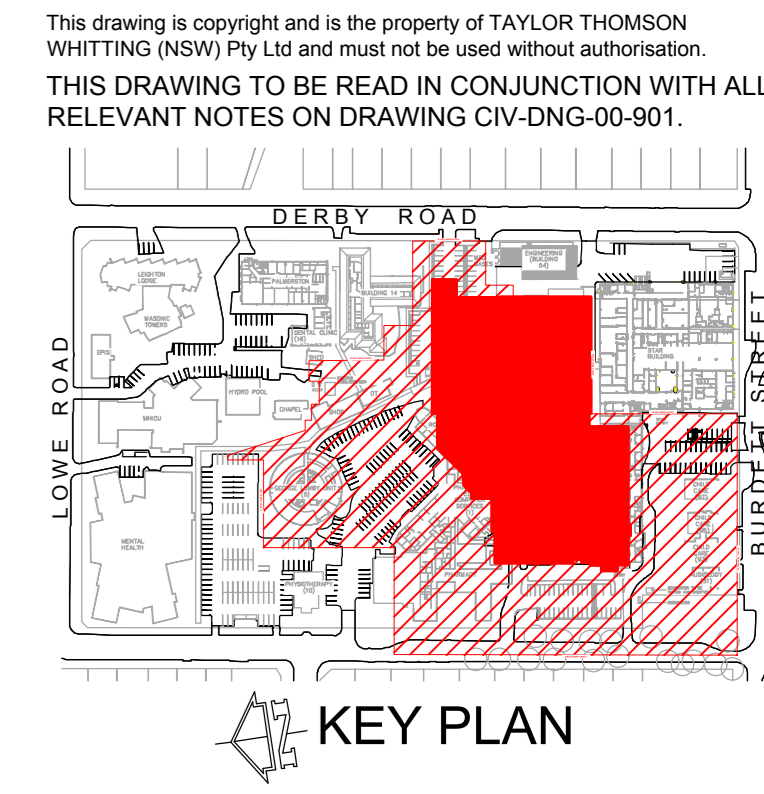

Rev	Description	Eng	Draft	Date
A	ISSUE FOR CONSTRUCTION	JH	JH	20.08.18

Architect: SILVER THOMAS HANLEY
3 Cleburn Road, Glen Iris Victoria 3146



Project: HORNSBY KU-RING-GAI HOSPITAL - STAGE 2
Palmerston Road, Hornsby NSW 2077
Sheet Subject: SECTIONS SHEET 2

Civil Engineer: **TTW Taylor Thomson Whitting**
612 9439 7288 | 48 Chandos Street St Leonards NSW 2065

Scale: AS Drawn: JH Authorised: [Signature]
AS SHOWN JH

Job No: 161607 CIV-DNG-40-902 Drawing No: A

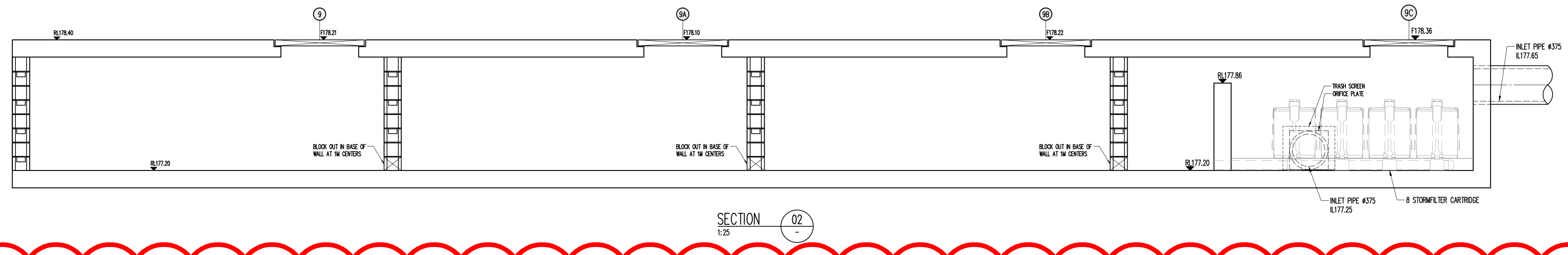
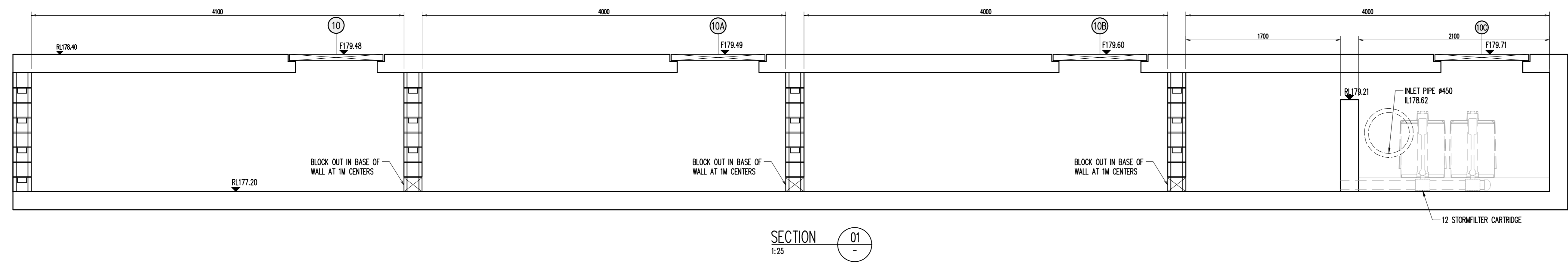
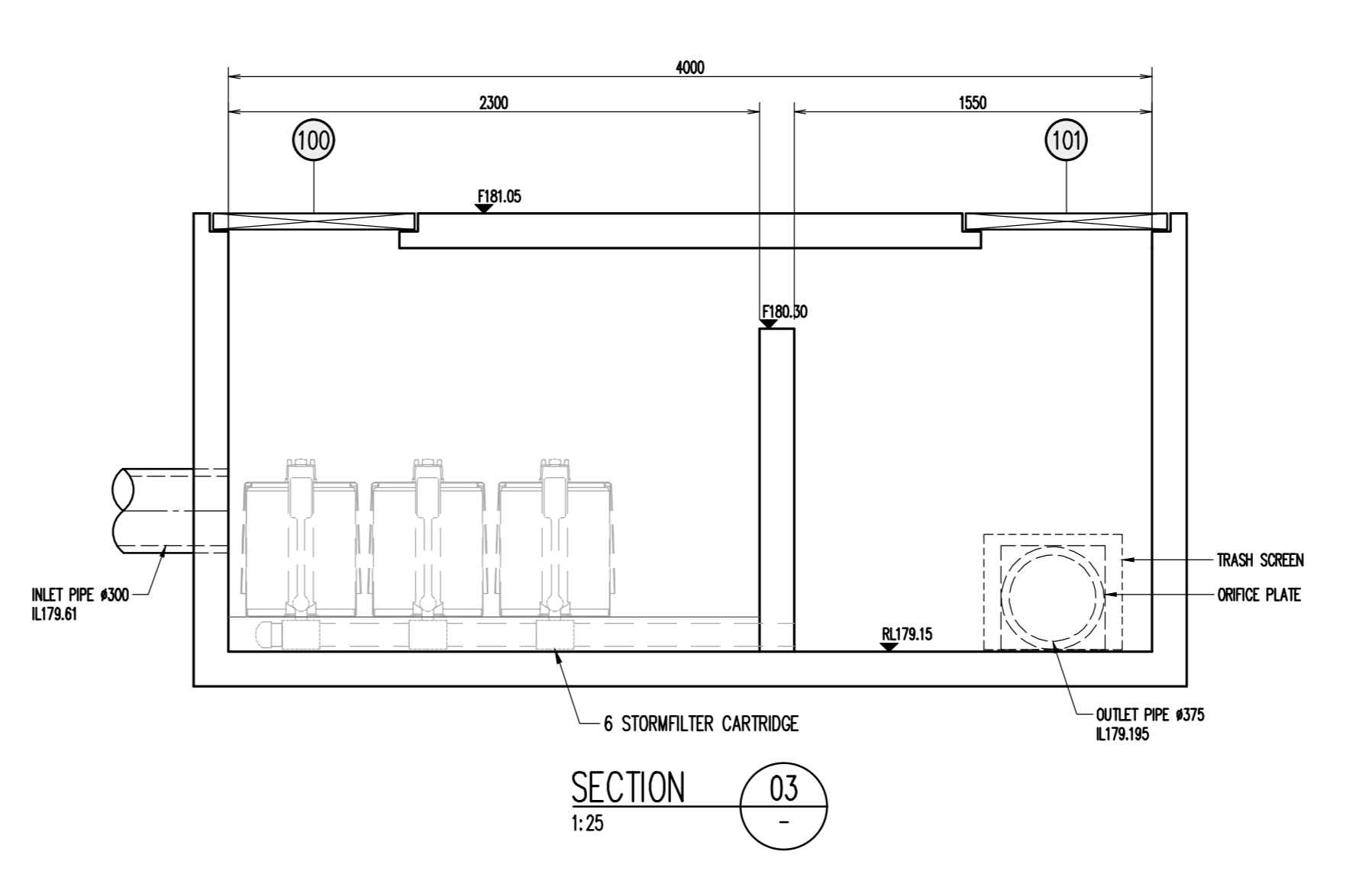
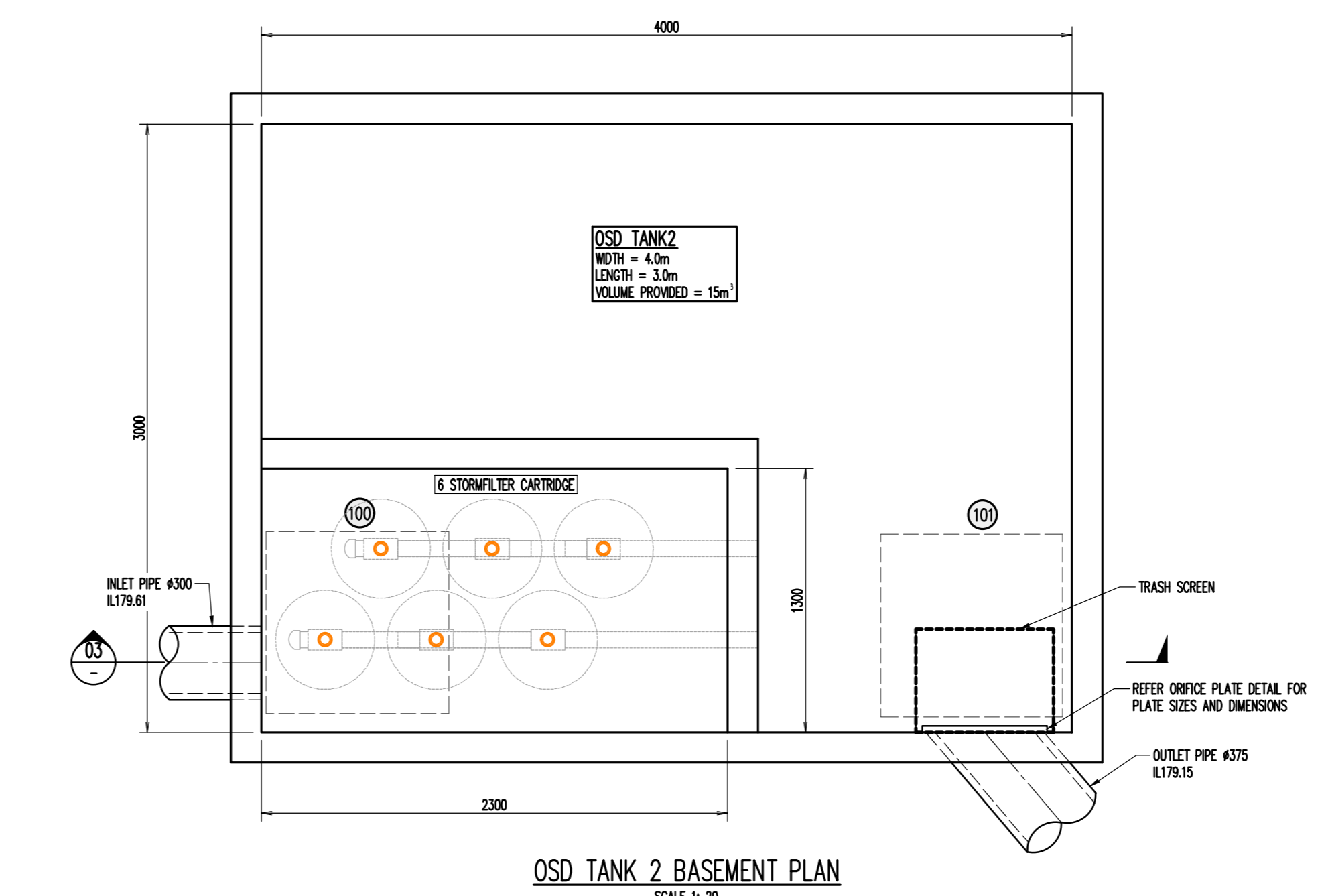
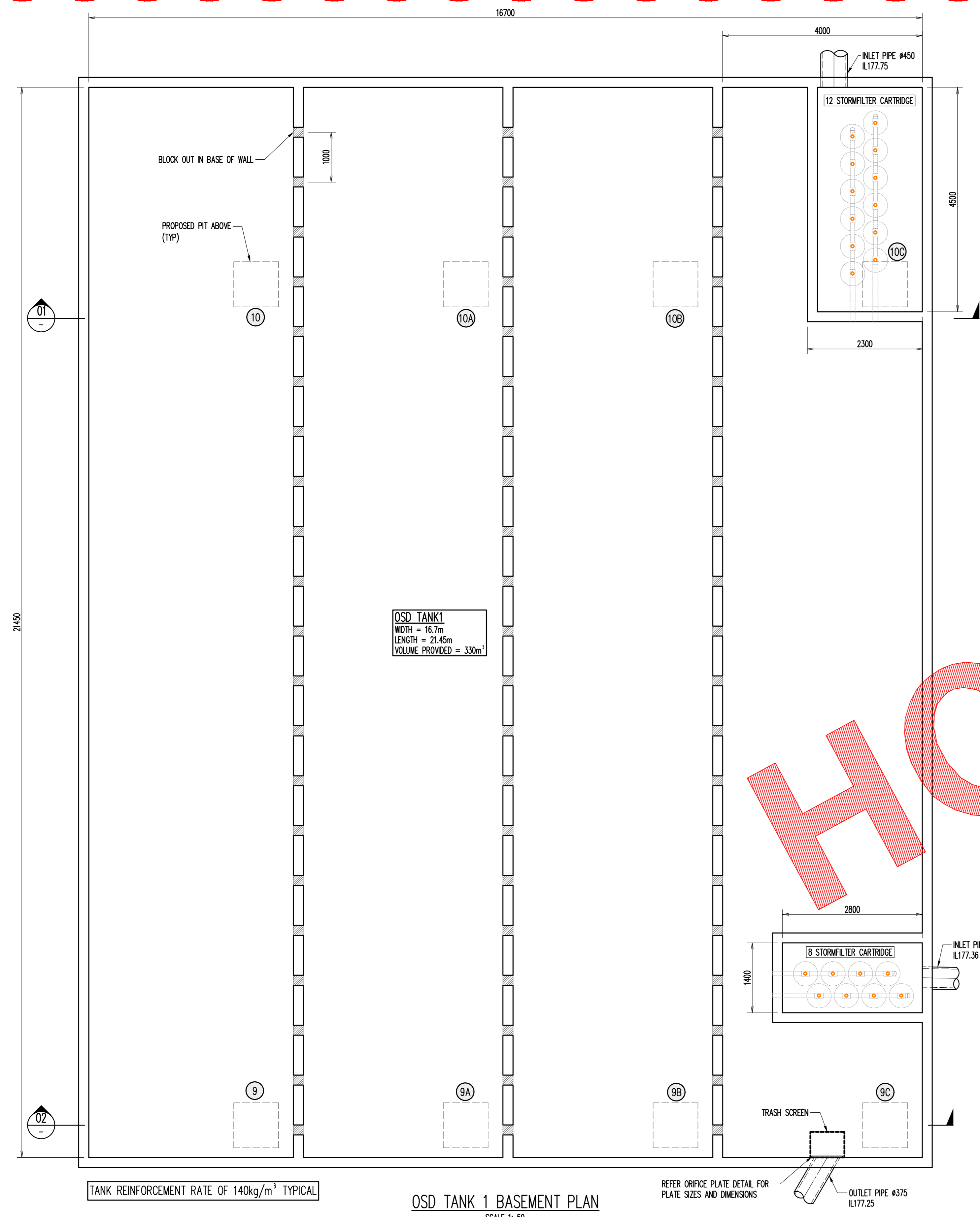
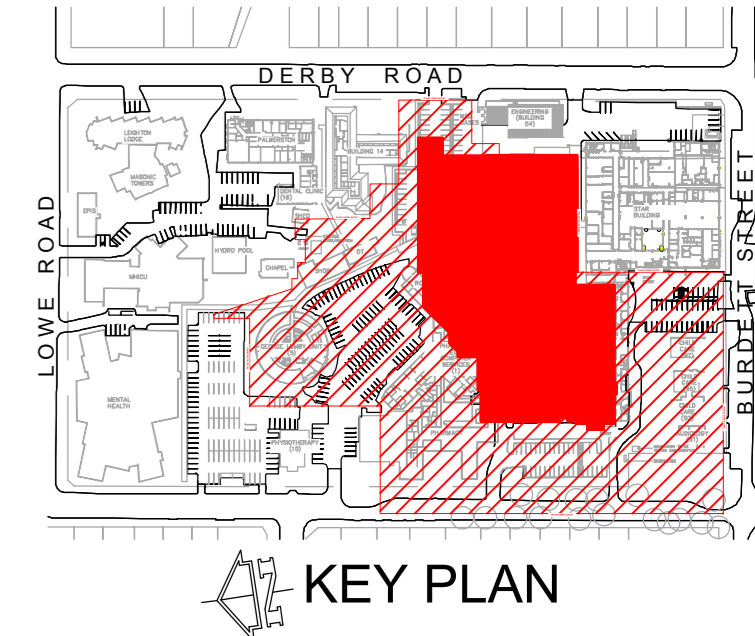

HOLD

Rev	Description	Eng	Draft	Date
A	ISSUE FOR CONSTRUCTION	BJH	JH	28.06.18

Architect: SILVER THOMAS HANLEY
3 Clarendon Road
Glen Iris Victoria 3146

Client: Health Infrastructure
Level 8, 77 Pacific Highway, North Sydney NSW 2060

Project: HORNSBY KU-RING-GAI HOSPITAL - STAGE 2
Palmerston Road, Hornsby NSW 2077

Sheet Subject: OSD TANK DETAILS SHEET

Civil Engineer: Taylor Thomson Whitting
612 9439 7288 | 48 Chandos Street St Leonards NSW 2055

Scale: A0 AS SHOWN
Drawing No: 161607 CIV-DNG-60-901
Revision: A

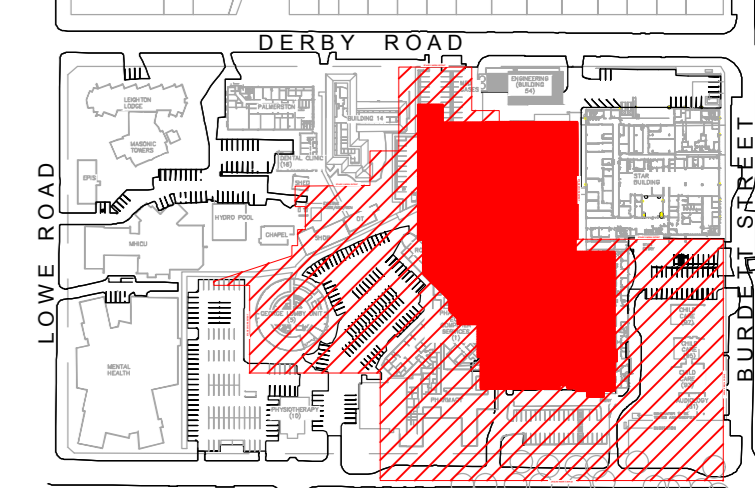

KEY PLAN

LINEMARKING LEGEND

	Edge line type E1
	Edge line type E5
	Barrier line
	Holding line
	Stop line

NOTE

Line marking to be in accordance with AS1742.2, AS2890.1, AS2890.2 AND AS2890.6

SIGNS AND LINE MARKING NOTES

1. Pavement marking and sign posting on public roads shall be in accordance with the requirements of the relevant Road Authority. The contractor shall obtain these requirements from the Road Authority.
2. Raised pavement markers to be in accordance with AS1742.2
3. Where existing pavement marking conflicts with proposed, it is to be removed.
4. Erect temporary sign 'changed traffic conditions ahead' 120m ahead of new work in both directions.
5. Establish the location of existing utility services and locate new signs clear of these installations.

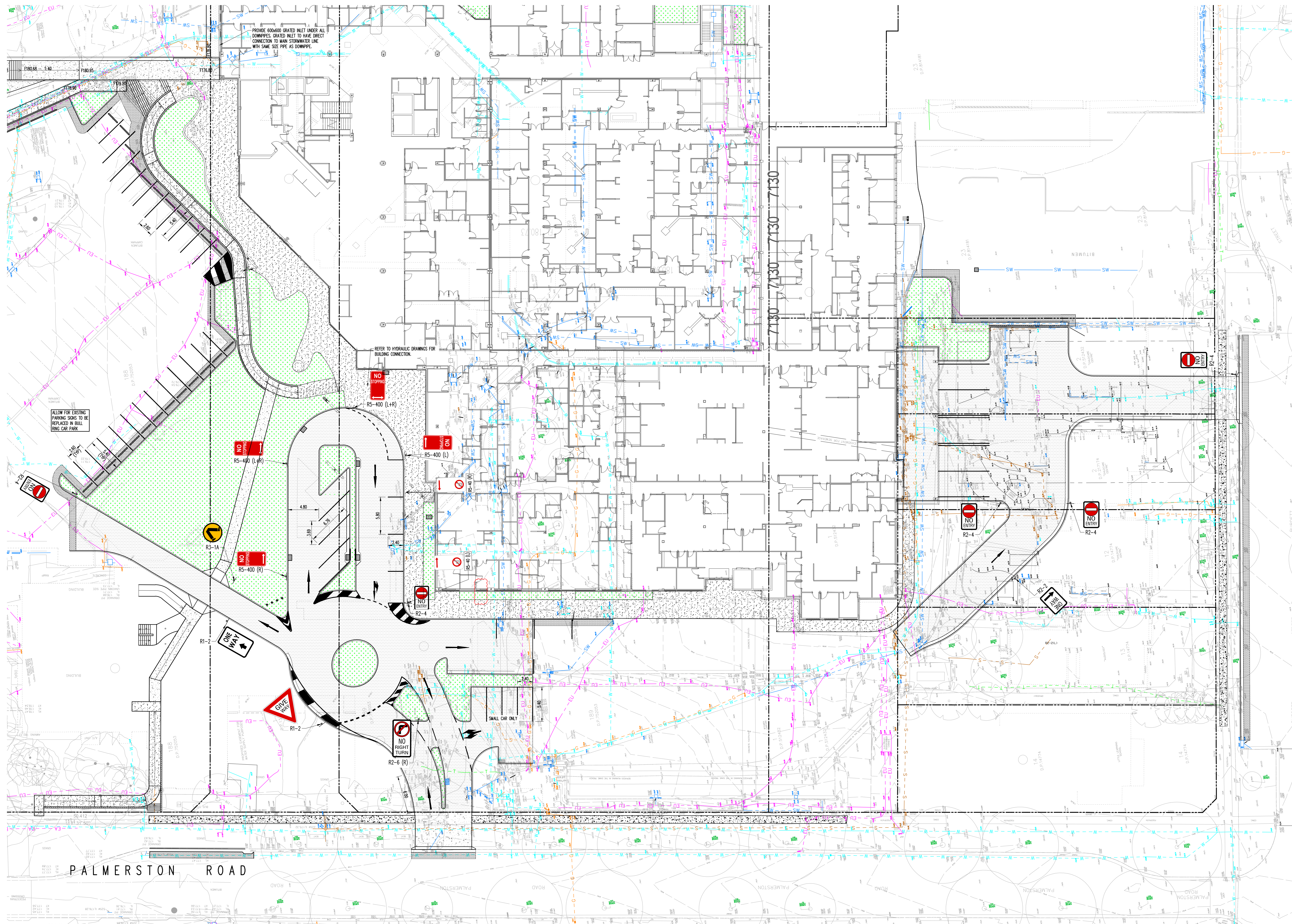

Rev	Description	Eng	Draft	Date
A	ISSUE FOR CONSTRUCTION	SH	JH	28.06.18

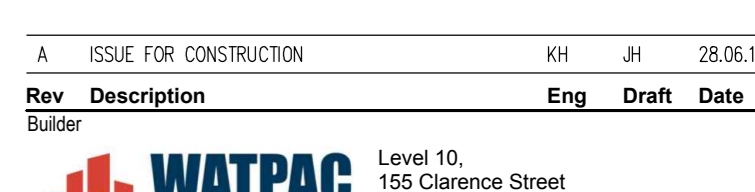

Architect: SILVER THOMAS HANLEY
3 Cleverly Road
Glen Iris Victoria 3146

Mechanical & Electrical	NSW
Hydraulic & Fire	NSW
Client	



Level 8, 77 Pacific Highway, North Sydney NSW 2060
Project: HORNBSBY KU-RING-GAI HOSPITAL - STAGE 2
Palmerston Road, Hornsby NSW 2077
Sheet Subject: MAIN ENTRY SIGNAGE PLAN



Civil Engineer
Scale: A0 1:200
Job No: 161607 CIV-DNG-70-901
Drawing No: A